



ALL WEATHER
ARCHITECTURAL ALUMINUM

SERIES 6200 HORIZONTAL SLIDING WINDOW SYSTEM

777 Aldridge Road | Vacaville, CA 95688 | 800.680.5800 | www.allweatheraa.com

SERIES 6200

3 1/8" HORIZONTAL SLIDING WINDOW SYSTEM

The Series 6200 Horizontal Sliding Window System is All Weather's newest, energy efficient window design. Featuring narrow sightlines and a contemporary aesthetic, the Series 6200 horizontal sliding window is ideal for residential, multi-family and commercial applications.

The Series 6200 Horizontal Sliding Window System meets Title 24 compliance using the Prescriptive Method, is commercially rated and delivers best in class STC ratings.

FEATURES

- 3 1/8" Frame with mitered corners
- Max panel width 48", min panel width 18"
- Max panel height 84", min panel height 18"
- Max panel size 48" x 84"
- Maximum of 28 square feet total or 180 lbs
- Thermally broken frame – Pour & Debridge system
- Extruded aluminum screen

FRAME OPTIONS

- Nail On, Block Frame

CONFIGURATIONS

- OX, XO and XOX
- Additional configurations coming soon

GLAZING OPTIONS

- XO, OX, XOX with fixed transoms above or fixed bottom lights

HARDWARE OPTIONS

- Amesbury Truth Positive Action Lock (PAL) in bronze or satin nickel finish
- Recessed finger pull
- Fapim Hockey rollers in single or double roller configuration depending upon weight of the panel
- Hockey rollers weight capacity 180 lbs
- Window Opening Control Device (WOCD)

FINISH OPTIONS

- Clear Anodized Class I (standard)
- Bronze Anodize Class I (standard)

RATINGS & CERTIFICATION

- NFRC Certified Product
- Dual glazed unit will hit 0.31 U factor
- Triple glazed unit will hit 0.25 U factor
- CW Performance Class with a PG35 rating
- Acoustically Rated

Sliding Window Assembly

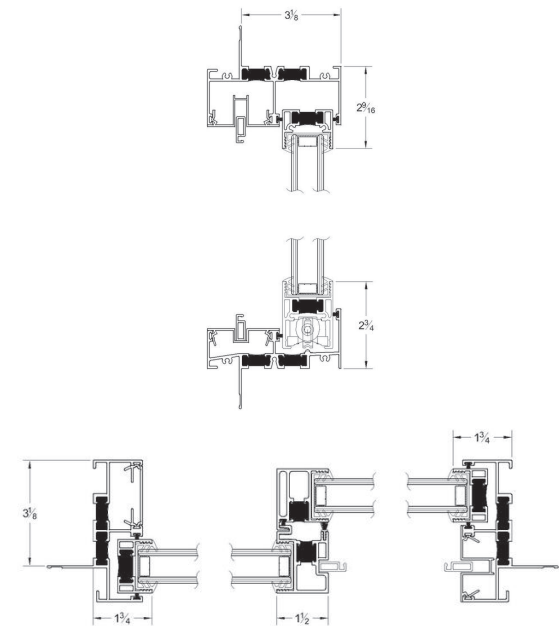

PAL Hardware



Fapim Hockey Roller



Recessed Finger Pull

