



ALL WEATHER  
ARCHITECTURAL ALUMINUM

## SERIES 8150 THERMALLY BROKEN ALUMINUM SLIDING DOOR

PRODUCT SPECIFICATIONS | EXTRUSION DETAILS | TEST REPORTS



## INTRODUCTION

Series 8150 product line uses 6063 extruded aluminum age hardened to a T-6 rating for strength and durability. The frame uses the pour-and-debridge method for thermal break. The panel profiles for this series are extruded as two separate parts and are then joined into a single profile using thermal struts. The aluminum extrusions are knurled and then crimped along the thermal profile to ensure a tight grip. The finished profile is now thermally broken providing both improved thermal performance as well as improved condensation resistance. We currently are using two 14.6 mm offset thermal strut in the frame, 31.9 struts in the lead stiles, top and bottom, and a 24 strut on the interlocker.

The series 8150 Sliding Doors is available in the following finishes:

- Class I Clear Anodized\*\*
- Class I Bronze Anodized\*\*
- Standard White
- Custom Anodized
- 70% Kynar Paint Color
- A combination of the above finishes on the Interior vs. Exterior
- Before the interior and exterior profiles are joined with the thermal strut, they can be painted or anodized with separate colors for a two-toned window.

\*\* Indicates Finishes In Stock.

## STRUCTURAL TESTING

Series 8150 sliding patio door meets AAMA standards as listed below: (Please see test reports located in the back of this section for door sizes.)

- Series 8150 Thermal Break Sliding Door XO – SD – CW35

All Weather has comprehensive files containing all historical testing. Each of the tests in the proceeding list are current, however, our archived testing may be more specific for your particular project and will be provided upon request.

## ACOUSTICAL TESTING

Series 8150 sliding patio door meets the following STC performance ratings:

- STC 33 / OITC 27 ¼" over ¾" with a 1" OA
- STC 33 / OITC 28 ¼" over 5/16" with a 1" OA
- STC 34 / OITC 30 ¼" over 3/8" Lami with a 1" OA

## THERMAL TESTING

Series 8150 sliding patio door has been simulated and tested according to NFRC 100/200/500.

- U-Factor as low as .32 at standard NFRC Size

## CONSTRUCTION

Corners of frame, vent and fixed panels are square cut and screwed together for structural integrity. All muntin and other intermediate bars are firmly attached to their cross joints and their abutting sash sections. The frame sill contains weep provisions. All surfaces to be glazed are marine glazed.

## HARDWARE

### Handles

Flush mount and pull handle options available.

### Rollers

Standard rollers are 1.8" stainless steel precision bearing rollers. QUADZilla roller option with low profile bottom rail.

## SCREENS

Screens are made of extruded aluminum to match the door panel profiles and use charcoal fiberglass mesh. Ultraview mesh is available upon request. Retractable screen option available.

## GLAZING

The Series 8150 offers a 1" OA on insulating glass units.

## WEATHER-STRIPPING

Our Series 8150 Sliding doors are weather stripped with pile weatherstripping. All of the weather-stripping utilizes triple-fin and quiet-fin technology to reduce noise during operation and improve weathering performance.

## INSTALLATION GUIDELINES

- Units ship with glazed panels and knock down frame for on-site assembly.
- All doors must be installed in prepared openings in accordance with AAMA recommendations and the below-listed manufacturers' recommendations.
- If shop drawings are required, please refer to approved shop drawings for installation.
- Each unit must be installed level, plumb and square with a 0.5" clearance on the jambs and the header of the door.
- For nail-on applications the header must not be nailed. You may place a nail ½ inch above the fin and bend it over the fin, to allow for header deflection.

- Remove wet plaster, mortar, stucco and cement immediately.  
**(Note: doors should only be cleaned with mild soap and water.)**
- Do not set items on the sill or use it for any other purpose.
- In nail-on applications, a bead of caulking material should be applied to the inside nail-on fin just before installation to insure a water-tight seal between the building and the door.
- Any attachment screws or bolts should be sealed during the process of installation.
- The 8000 frame is hollow so a clearance hole for the head of the fastener should be used to fasten the outer most web to the building. The head of the fastener must be sealed to the frame and the clearance hole should be filled and capped.
- After installation is completed, building paper and stucco wire, if a stucco application, should overlap the window nail-on flange.

## CARE & MAINTENANCE

- Doors should be kept free of all dust, dirt, paint and plaster.
- The sill should be kept clean at all times. A vacuum cleaner with a crevice attachment is recommended.
- Doors should only be cleaned with mild soap and water.
- **Caution: Damage will occur to the finish and to the sealed glass unit if solvents, petroleum products, or caustic chemicals, such as acetone or paint thinner are used to clean window frames. Damage caused by this type of abuse is not covered under warranty.**





**8152 FRAME HEAD**

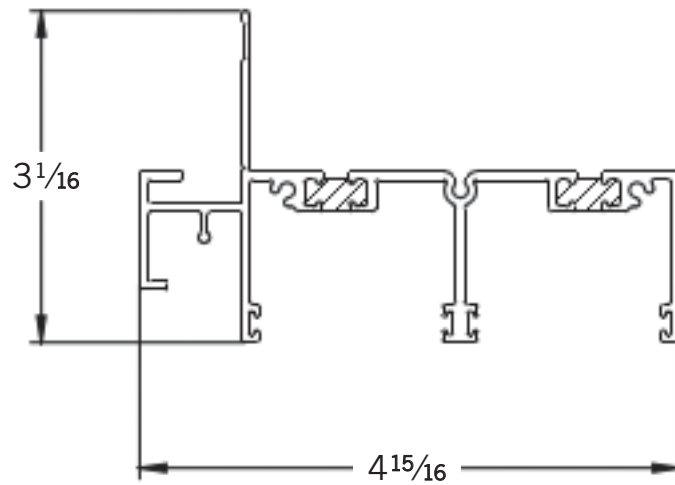

**8153 FRAME JAMB**

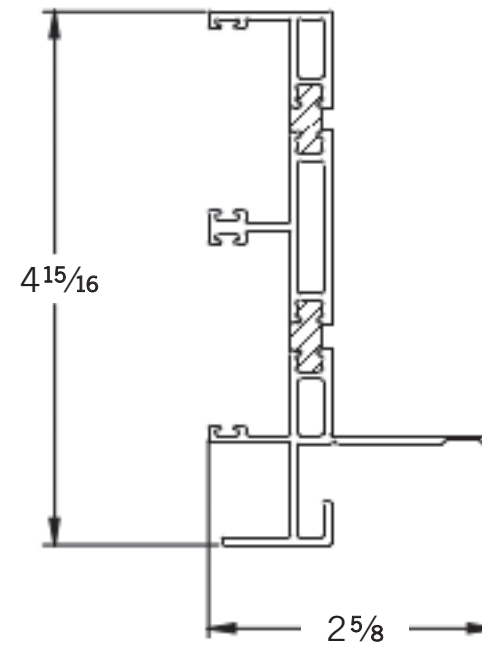



**8154 FRAME SILL  $1\frac{7}{8}$ "**

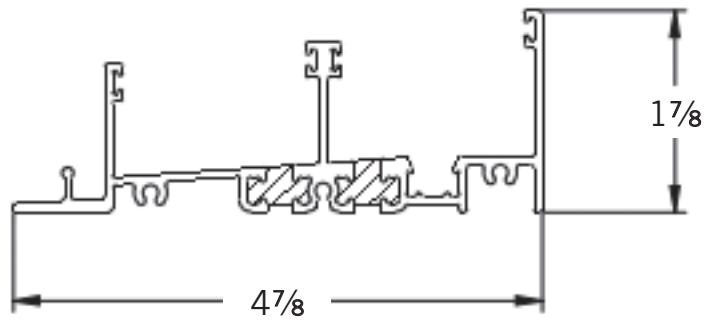

**8155 FRAME SILL  $\frac{3}{4}$ "**

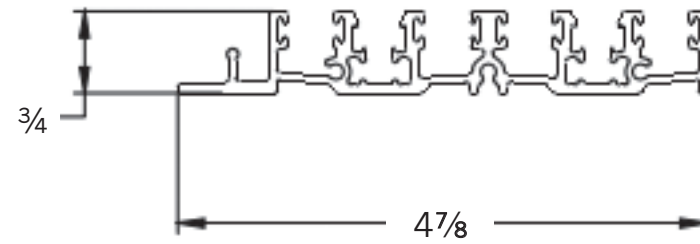



**8101 TOP RAIL**

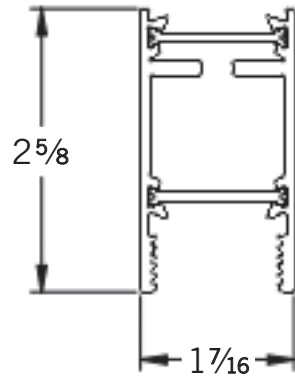

**8156 BOTTOM RAIL**

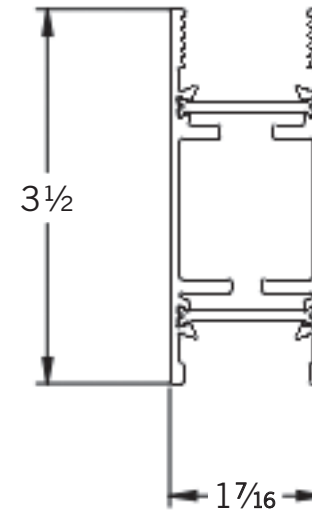



**8103 LEAD STILE**

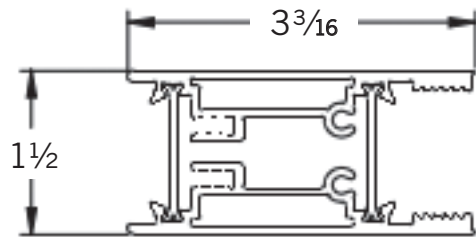

**8104 ACTIVE INTERLOCK**

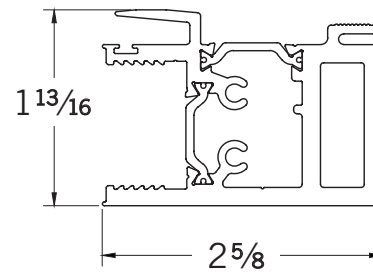

**8104 INACTIVE INTERLOCK**

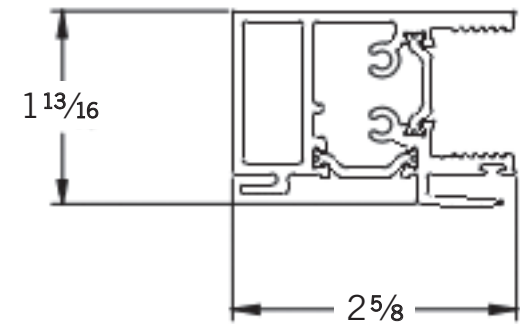



**811 THRESHOLD**

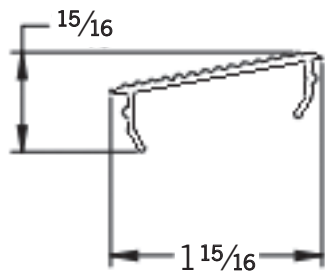

**812 TRIM CAP**

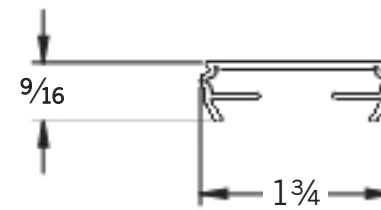



**OX SLIDING DOOR**

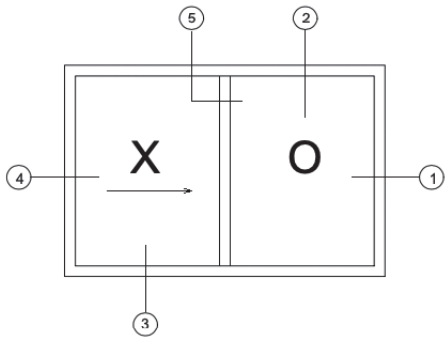

**1**

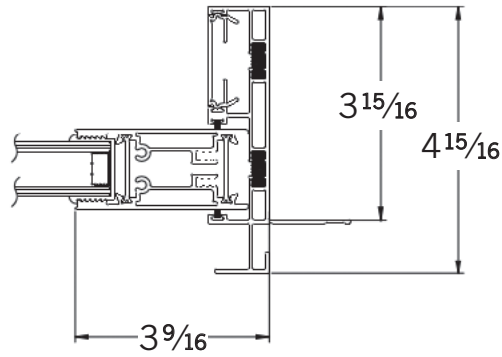

**2**

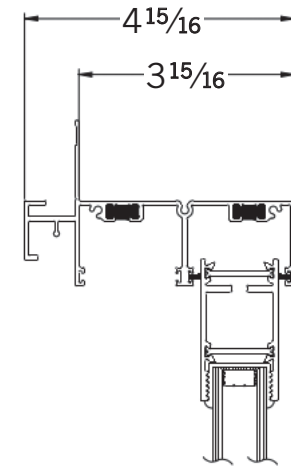

**3**

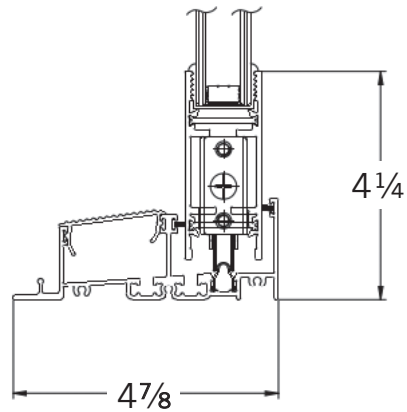

**4**

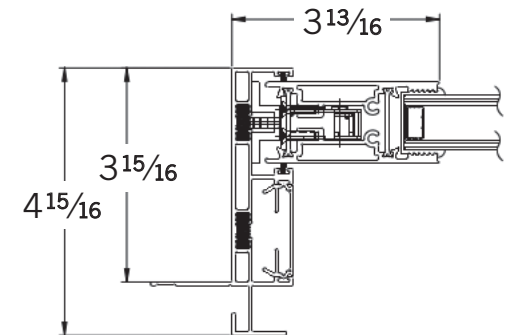

**OXXO SLIDING DOOR**

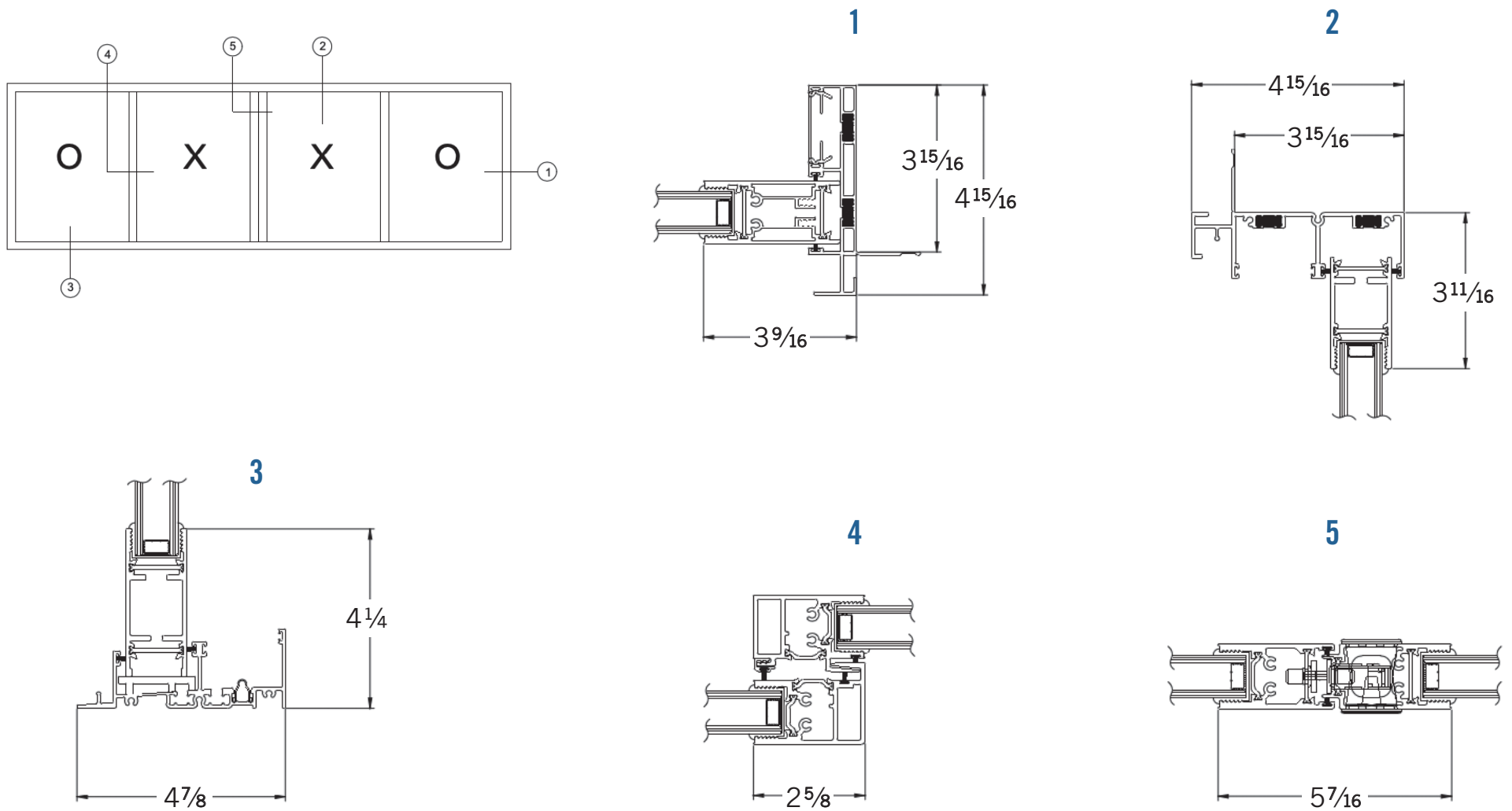

**intertek**  
Total Quality. Assured.

# ALL WEATHER ARCHITECTURAL ALUMINUM TEST REPORT

**SCOPE OF WORK**

AAMA/WDMA/CSA 101/I.S.2/A440 TESTING ON 8150 SLIDING GLASS DOOR, NOMINAL SIZE 95 X 83

**REPORT NUMBER**

L4626.01-301-44 R0

**TEST DATES**

09/15/20 - 10/19/20

**ISSUE DATE**

04/16/21

**RECORD RETENTION END DATE**

10/19/30

**PAGES**

25

**DOCUMENT CONTROL NUMBER**

RT-R-AMER-Test-2804 (04/17/18)

© 2017 INTERTEK

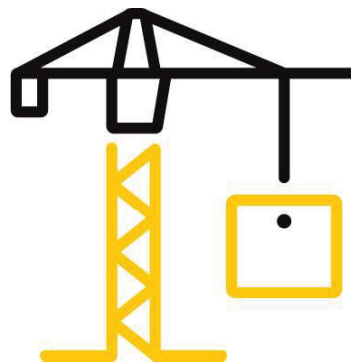

**intertek**  
Total Quality. Assured.

2524 E. Jensen Ave  
Fresno, California 93706

Telephone: 559-233-8705  
Facsimile: 717-764-4129  
www.intertek.com/building

**TEST REPORT FOR ALL WEATHER ARCHITECTURAL ALUMINUM**

Report No.: L4626.01-301-44 R0

Date: 04/16/21

**REPORT ISSUED TO**

**ALL WEATHER ARCHITECTURAL ALUMINUM**

777 Aldridge Road  
Vacaville, California 95688

**SECTION 1**

**SCOPE**

Intertek Building & Construction (B&C) was contracted by All Weather Architectural Aluminum to perform testing in accordance with AAMA/WDMA/CSA 101/I.S.2/A440 on their 8150 Sliding Glass Door. Results obtained are tested values and were secured by using the designated test method(s). Testing was conducted at the Intertek B&C test facility in Fresno, California. This report does not constitute certification of this product nor an opinion or endorsement by this laboratory.

**SECTION 2**

**SUMMARY OF TEST RESULTS**

TITLE	RESULTS
AAMA/WDMA/CSA 101/I.S.2/A440-17	Class CW – PG35 Size Tested: 2402 x 2103 mm (95 x 83 in) Type SD
Air Infiltration	1.2 L/s/m <sup>2</sup> (0.23 cfm/ft <sup>2</sup> )
Canadian Air Infiltration/Exfiltration	A2 Operable
Water Penetration Resistance	260 Pa (5.43 psf)
Design Pressure	±1680 Pa (±35.09 psf)

For INTERTEK B&C:

**COMPLETED BY:** Ricardo Cortez

**REVIEWED BY:** Tyler Westerling, P.E.

**TITLE:** Technician

**TITLE:** Operations Manager

**SIGNATURE:**

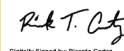

Digitally Signed by: Ricardo Cortez



Digitally Signed by: Tyler Westerling

**DATE:** 04/16/21

**DATE:** 04/16/21

RC:ms

This report is for the exclusive use of Intertek's Client and is provided pursuant to the agreement between Intertek and its Client. Intertek's responsibility and liability are limited to the terms and conditions of the agreement. Intertek assumes no liability to any party, other than to the Client in accordance with the agreement, for any loss, expense or damage occasioned by the use of this report. Only the Client is authorized to permit copying or distribution of this report and then only in its entirety. Any use of the Intertek name or one of its marks for the sale or advertisement of the tested material, product or service must first be approved in writing by Intertek. The observations and test results in this report are relevant only to the sample(s) tested. This report by itself does not imply that the material, product, or service is or has ever been under an Intertek certification program.

Version: 04/17/18

Page 2 of 25

RT-R-AMER-Test-2804



Total Quality. Assured.

**TEST REPORT FOR ALL WEATHER ARCHITECTURAL ALUMINUM**

Report No.: L4626.01-301-44 R0  
Date: 04/16/21

**SECTION 3  
TEST SPECIFICATION(S)/METHOD(S)**

The specimens were evaluated in accordance with the following:

**AAMA/WDMA/CSA 101/I.S.2/A440-17** - North American Fenestration Standard/Specification for Windows, Doors, and Skylights

The following test methods were used during testing:

**ASTM E2068-00(2016)**, Standard Test Method for Determination of Operating Force of Sliding Windows and Doors1

**ASTM E283-04(2012)**, Standard Test Method for Determining Rate of Air Leakage Through Exterior Windows, Curtain Walls, and Doors Under Specified Pressure Differences Across the Specimen

**ASTM E547-00(2016)**, Standard Test Method for Water Penetration of Exterior Windows, Skylights, Doors, and Curtain Walls by Cyclic Static Air Pressure Difference

**ASTM E330/E330M-14**, Standard Test Method for Structural Performance of Exterior Windows, Doors, Skylights and Curtain Walls by Uniform Static Air Pressure Difference

**ASTM F842-17**, Standard Test Methods for Measuring the Forced Entry Resistance of Sliding Door Assemblies, Excluding Glazing Impact

**ASTM E987-88(2017)**, Standard Test Methods for Deglazing Force of Fenestration Products

**SECTION 4  
MATERIAL SOURCE/INSTALLATION**

Test specimen was provided by the client. Representative samples of the test specimen(s) will be retained by Intertek B&C for a minimum of three years from the test completion date.

The specimen was installed into a Douglas-Fir wood buck. The rough opening allowed for a 1/4" shim space at Sill and right Jamb. and the exterior perimeter of the specimen was sealed to the test buck.

LOCATION	ANCHOR DESCRIPTION	ANCHOR SPACING
Head	#6 x 1-5/8" Philips flat head wood screw	1" from corner, 12" on center
Jambs	#6 x 1-5/8" Philips flat head wood screw	1" from corners, 11-1/2" on center
Sill	Set in sealant	Fully bedded



Total Quality. Assured.

**TEST REPORT FOR ALL WEATHER ARCHITECTURAL ALUMINUM**

Report No.: L4626.01-301-44 R0  
Date: 04/16/21

**SECTION 5  
LIST OF OFFICIAL OBSERVERS**

NAME	COMPANY
Dennis Janzen	Intertek B&C
Tyler Westerling, P.E.	Intertek B&C

**SECTION 6  
TEST SPECIMEN DESCRIPTION**

**Product Type:** Sliding Door  
**Series/Model:** 8150 Sliding Glass Door

**Product Sizes:**

OVERALL AREA:	WIDTH		HEIGHT	
	Millimeters	Inches	Millimeters	Inches
5.05 m <sup>2</sup> (54.4 ft <sup>2</sup> )				
Overall size	2402	94-9/16	2103	82-13/16
Operable panel	1210	47-5/8	2055	80-7/8
Fixed Panel	1235	48-5/8	2055	80-7/8

**Frame Construction:**

MEMBER	MATERIAL	DESCRIPTION
Head, Sill, Jambs	Aluminum	Thermally broken
JOINERY TYPE		DETAIL
All corners	Butted	Screwed and Sealed

**Panel Construction:**

MEMBER	MATERIAL	DESCRIPTION
Rails, Stiles	Aluminum	Thermally broken
JOINERY TYPE		DETAIL
All corners	Butted	Screwed and Sealed

**Reinforcement:** No reinforcement was utilized.



Total Quality. Assured.

**TEST REPORT FOR ALL WEATHER ARCHITECTURAL ALUMINUM**

Report No.: L4626.01-301-44 R0  
Date: 04/16/21

2524 E. Jensen Ave  
Fresno, California 93706  
Telephone: 559-233-8705  
Facsimile: 717-764-4129  
www.intertek.com/building

**Weatherstripping:**

DESCRIPTION	QUANTITY	LOCATION
Polypile with center fin	1 row	Perimeter of operable panel
Polypile with center fin	1 row	Fixed Meeting stile

**Glazing:** No conclusions of any kind regarding the adequacy or inadequacy of the glass in any glazed test specimen(s) can be made.

GLASS TYPE	SPACER TYPE	LITE COMPOSITION	GLAZING METHOD
1" IG	Foam	3/16" tempered, Interior/Exterior	Rubber Glazing Bead, Interior and exterior wet glazed

LOCATION	QUANTITY	DAYLIGHT OPENING	GLASS BITE
		Millimeters	Inches
Panel	1 per panel	1060 x 1890	41-3/4 x 74-7/16 1/2"

**Drainage:**

METHOD	SIZE	QUANTITY	LOCATION
Weep with slot	1-1/4" wide by 1/4" high	2	1/2" from jamb, on sill

**Hardware:**

DESCRIPTION	QUANTITY	LOCATION
Lock and keeper	1	48" from sill, on lock jamb
Handle	1	41" from sill, lock stile
Roller Assembly	1 set	Operable panel – bottom rail
Roller track	1	Full span of operable panel channel sill

**Screen Construction:** No screen was utilized.



Total Quality. Assured.

**TEST REPORT FOR ALL WEATHER ARCHITECTURAL ALUMINUM**

Report No.: L4626.01-301-44 R0  
Date: 04/16/21

2524 E. Jensen Ave  
Fresno, California 93706  
Telephone: 559-233-8705  
Facsimile: 717-764-4129  
www.intertek.com/building

**SECTION 7**

**TEST RESULTS**

The temperature during testing was 24°C (75°F) Controlled environment. The results are tabulated as follows:

TITLE OF TEST	RESULTS	ALLOWED	NOTE
<b>Operating Force,</b> per ASTM E2068	Initiate Motion: 125 N (28 lbf) Maintain Motion: 107 N (24 lbf) Latches: 62 N (14 lbf)	135 N (30.35 lbf) max  110 N (24.73 lbf) max  Report only	
<b>Air Leakage,</b> Infiltration per ASTM E283 at 75 Pa (1.57 psf)	1.2 L/s/m <sup>2</sup> (0.23 cfm/ft <sup>2</sup> )	<u>Maximum</u> 1.5 L/s/m <sup>2</sup> (0.3 cfm/ft <sup>2</sup> )	1, 2
<b>Air Leakage,</b> Exfiltration per ASTM E283 at 75 Pa (1.57 psf)	1.0 L/s/m <sup>2</sup> (0.20 cfm/ft <sup>2</sup> )	<u>Maximum</u> 1.5 L/s/m <sup>2</sup> (0.3 cfm/ft <sup>2</sup> )	1, 2
<b>Canadian Air Infiltration/Exfiltration Level</b>	A2 Operable	N/A	
<b>Water Penetration,</b> per ASTM E547 at 260 Pa (5.43 psf)	Pass	No leakage	
<b>Uniform Load Deflection,</b> per ASTM E330 Deflections taken at <u>Interlock</u> +1680 Pa (+35.09 psf) -1680 Pa (-35.09 psf)	11.0 mm (0.44") 11.4 mm (0.45")	<u>Maximum:</u> 11.6 mm (0.46") 11.6 mm (0.46")	3, 4
<b>Uniform Load Structural,</b> per ASTM E330 Permanent set taken at <u>Interlock</u> +2520 Pa (+52.63 psf) -2520 Pa (-52.63 psf)	0.4 mm (0.02") 0.3 mm (0.01")	<u>Maximum:</u> 8.1 mm (0.32") 8.1 mm (0.32")	3, 4
<b>Forced Entry Resistance,</b> per ASTM F842, Type: A - Grade: 20	Pass	No entry	
<b>Deglazing,</b> per ASTM E987 Operating direction, 320 N (70 lbf) Remaining direction, 230 N (50 lbf)	Pass  Pass	Meets as stated  Meets as stated	

**intertek**

Total Quality. Assured.

**TEST REPORT FOR ALL WEATHER ARCHITECTURAL ALUMINUM**

Report No.: L4626.01-301-44 R0

Date: 04/16/21

**Note 1:** The tested specimen meets (or exceeds) the performance levels specified in AAMA/WDMA/CSA 101/I.S.2/A440 for air leakage resistance.

**Note 2:** Test Date 10/15/20, Time: 12:52 PM

**Note 3:** Loads were held for 10 seconds.

**Note 4:** Tape and film were used to seal against air leakage during structural testing. In our opinion, the tape and film did not influence the results of the test.

**SECTION 8  
ALTERATIONS**

No alterations were required.

2524 E. Jensen Ave  
Fresno, California 93706  
Telephone: 559-233-8705  
Facsimile: 717-764-4129  
www.intertek.com/building

**intertek**

Total Quality. Assured.

**TEST REPORT FOR ALL WEATHER ARCHITECTURAL ALUMINUM**

Report No.: L4626.01-301-44 R0

Date: 04/16/21

**SECTION 9  
LOCATION OF AIR SEAL**

The air seal between the test specimen and the test wall is detailed below. The seal is made of foam weatherstripping and is attached to the edge of the test specimen buck. The test specimen buck is placed against the test wall and clamped in place, compressing the weatherstripping and creating a seal.

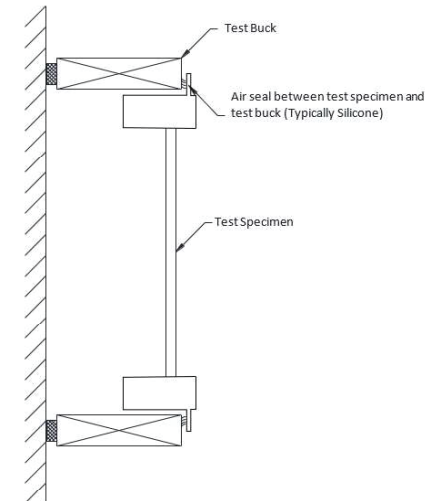

**SECTION 10  
CONCLUSION**

The specimen tested successfully met the performance requirements for the following rating:

**Class CW – PG35 Size Tested: 2402 x 2103 mm (95 x 83 in) Type SD**





**intertek**

Total Quality. Assured.

2524 E. Jensen Ave  
Fresno, California 93706

Telephone: 559-233-8705  
Facsimile: 717-764-4129  
www.intertek.com/building

**TEST REPORT FOR ALL WEATHER ARCHITECTURAL ALUMINUM**

Report No.: L4626.01-301-44 R0

Date: 04/16/21

**SECTION 11  
DRAWINGS**

The test specimen drawings have been reviewed by Intertek B&C and are representative of the test specimen(s) reported herein. Test specimen construction was verified by Intertek B&C per the drawings included in this report. Any deviations are documented herein or on the drawings.