



ALL WEATHER
ARCHITECTURAL ALUMINUM

SERIES 8100 THERMALLY BROKEN ALUMINUM MULTI SLIDE DOOR

PRODUCT SPECIFICATIONS | EXTRUSION DETAILS | TEST REPORTS

INTRODUCTION

Series 8100 product line uses 6063 extruded aluminum age hardened to a T-6 rating for strength and durability. Frame profiles are pour and debridge, and panel profiles are strutted. The profiles for this series are extruded as two separate parts and are then joined into a single profile using thermal struts. The aluminum extrusions are knurled and then crimped along the thermal profile to ensure a tight grip. The finished profile is now thermally broken providing both improved thermal performance as well as improved condensation resistance.

The Series 8100 Multi Slide Door is available in the following finishes:

- Class I Clear Anodized**
- Class I Bronze Anodized**

** Indicates Finishes In Stock.

STRUCTURAL TESTING

Series 8100 sliding patio door meets AAMA standards as listed below: (Please see test reports located in the back of this section for door sizes.)

- Series 8100 Thermal Break Sliding Door OX – SD

All Weather has comprehensive files containing all historical testing. Each of the tests in the proceeding list are current, however, our archived testing may be more specific for your particular project and will be provided upon request.

ACOUSTICAL TESTING

Series 8100 sliding patio door meets the following STC performance ratings:

- STC 34 / OITC 27 3/16" over 3/16" with a 1" OA
- STC 33 / OITC 26 1/4" over 1/4" with a 1" OA
- STC 38 / OITC 31 3/16" over 3/8" Lami with a 1" OA
- STC 38 / OITC 30 1/4" over 3/8" Lami with a 1" OA

THERMAL TESTING

Series 8100 sliding patio door has been simulated and tested according to NFRC 100/200/500.

- U-Factor as low as .30 at standard NFRC Size

CONSTRUCTION

Corners of frame, vent and fixed panels are square cut and screwed together for structural integrity. All muntin and other intermediate bars are firmly attached to their cross joints and their abutting sash sections. The frame sill contains weep provisions. All surfaces to be glazed are marine glazed.

HARDWARE

Handles

Flush mount and pull handle options available.

Rollers

Standard rollers are 3" stainless steel precision bearing rollers. QUADZilla roller option with low profile bottom rail.

SCREENS

Screens are made of extruded aluminum to match the door panel profiles and use charcoal fiberglass mesh. Ultraview mesh is available upon request. Retractable screen option available.

GLAZING

The Series 8100 offers a 1" OA on insulating glass units.

WEATHER-STRIPPING

Our Series 8100 Sliding patio doors are weather stripped with pile weather-stripping. All of the weather-stripping utilizes triple-fin and quiet-fin technology to reduce noise during operation and improve weathering performance.

INSTALLATION GUIDELINES

- Units ship with glazed panels and knock down frame for on-site assembly.
- All doors must be installed in prepared openings in accordance with AAMA recommendations and the below-listed manufacturers' recommendations. If shop drawings are required, please refer to approved shop drawings for installation.
- Each unit must be installed level, plumb and square with a ¼" clearance on the jambs and the header of the door.
- For nail-on applications the header must not be nailed. You may place a nail ½ inch above the fin and bend it over the fin, to allow for header deflection.
- Remove wet plaster, mortar, stucco and cement immediately.
(Note: doors should only be cleaned with mild soap and water.)
- Do not set items on the sill or use it for any other purpose.

- In nail-on applications, a bead of caulking material should be applied to the inside nail-on fin just before installation to insure a water-tight seal between the building and the door.
- Any attachment screws or bolts should be sealed during the process of installation.
The 8100 frame is hollow so a clearance hole for the head of the fastener should be used to fasten the outer most web to the building. The head of the fastener must be sealed to the frame and the clearance hole should be filled and capped.
- After installation is completed, building paper and stucco wire, if a stucco application, should overlap the window nail-on flange.

CARE & MAINTENANCE

- Doors should be kept free of all dust, dirt, paint and plaster.
- The sill should be kept clean at all times. A vacuum cleaner with a crevice attachment is recommended.
- Doors should only be cleaned with mild soap and water.
- **Caution:** Damage will occur to the finish and to the sealed glass unit if solvents, petroleum products, or caustic chemicals, such as acetone or paint thinner are used to clean window frames. Damage caused by this type of abuse is not covered under warranty.



81211 HEAD

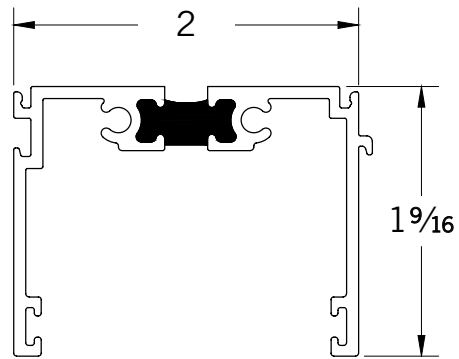

81221F RECESSED TILE SILL

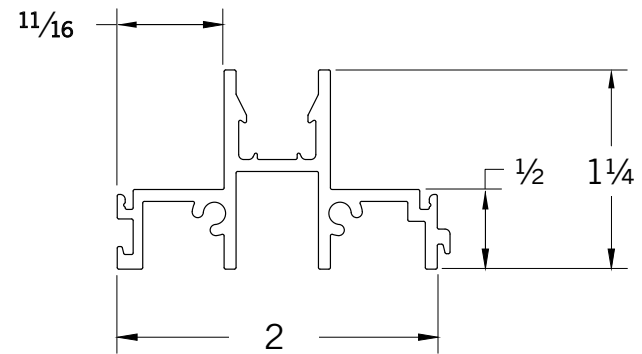



81221 LOW PROFILE SILL

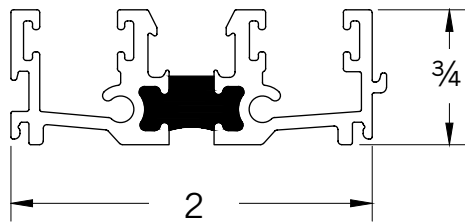

81223 MID RISE SILL

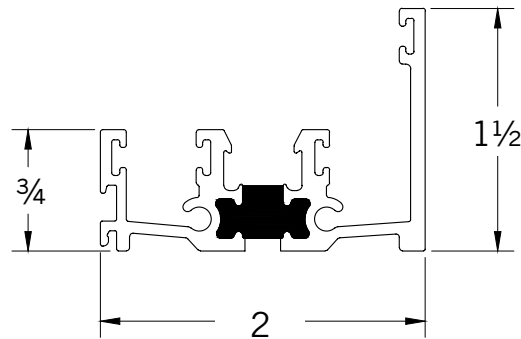

81222 2" SILL

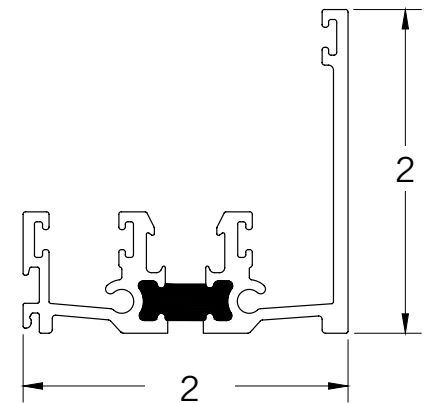



81231 JAMB

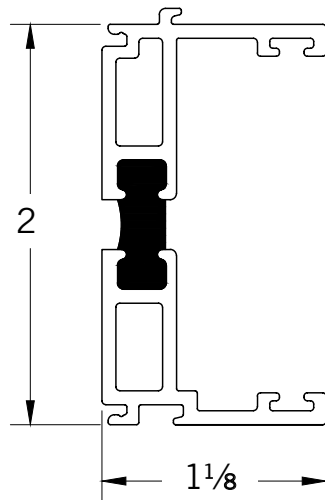

8151 NAIL FIN ADAPTER

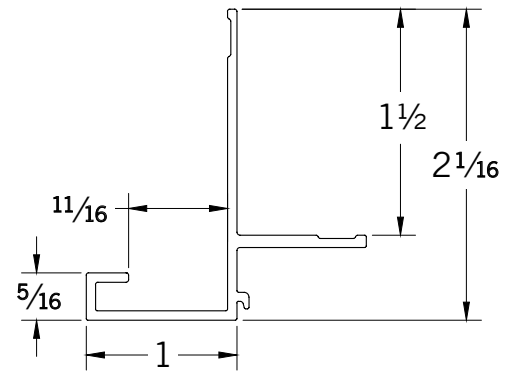



8195 POCKET INTERLOCK

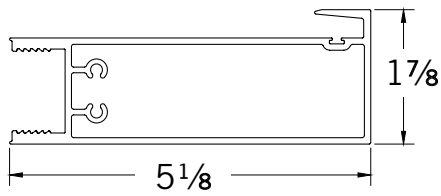

8197 POCKET WALL PROFILE

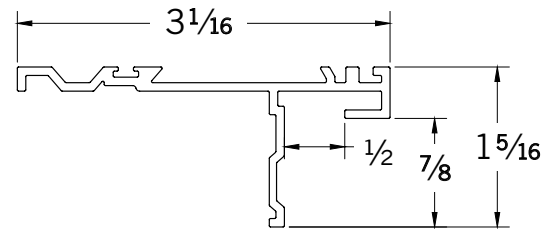

8198 POCKET WALL PROFILE

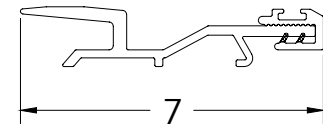



8101 TOP RAIL

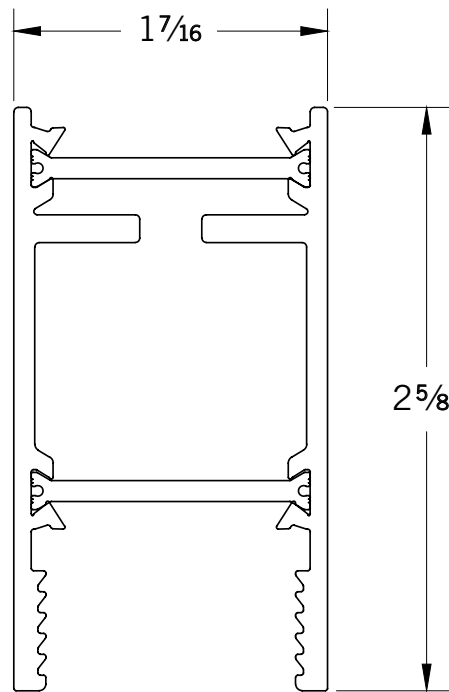

8102 BOTTOM RAIL

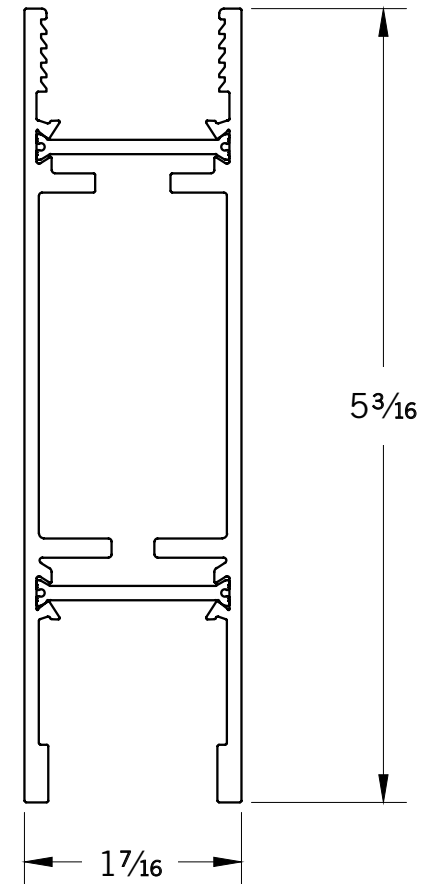



81020 LOW PROFILE
BOTTOM RAIL

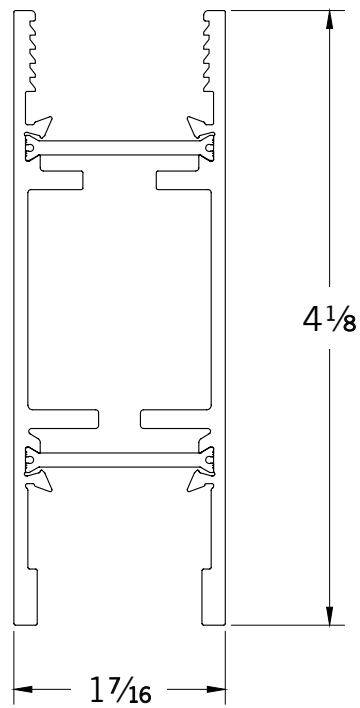

8102F RECESSED TILE SILL
BOTTOM RAIL

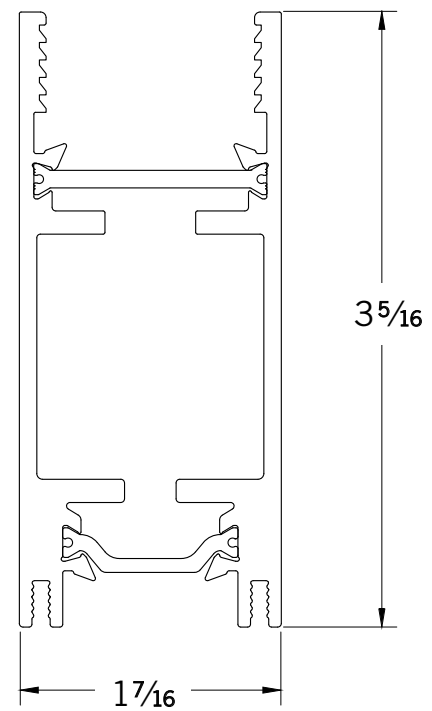



8109 LOW PROFILE
LEAD STILE

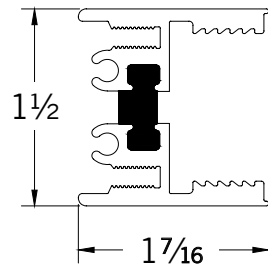

8117 CORNER STILE

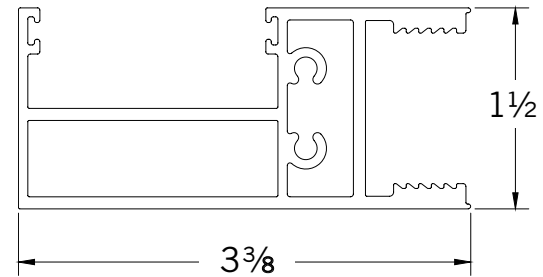



8103 LEAD STILE

8104 INTERLOCK

8105 INTERIOR INTERLOCK

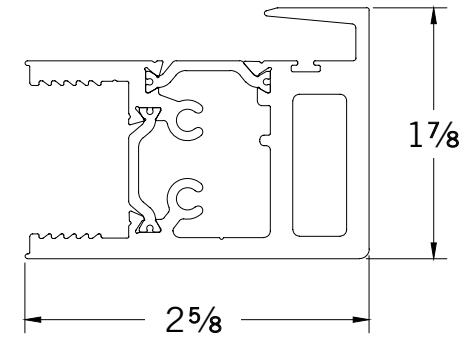
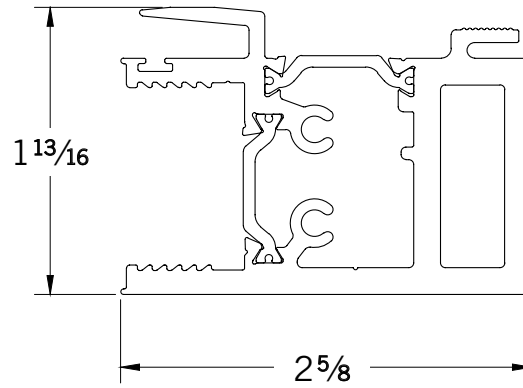
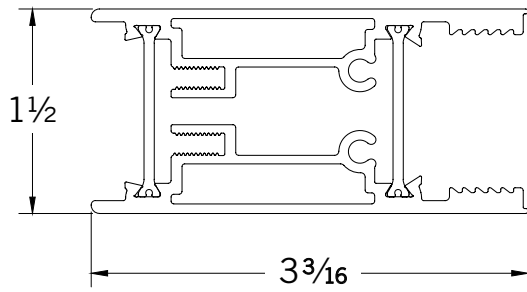



8106 ACTIVE
BI-PARTING STILE

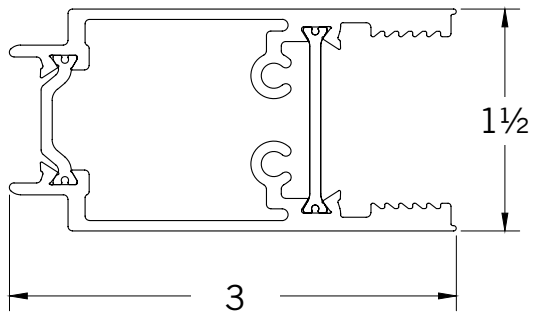

8107 INACTIVE
BI-PARTING STILE

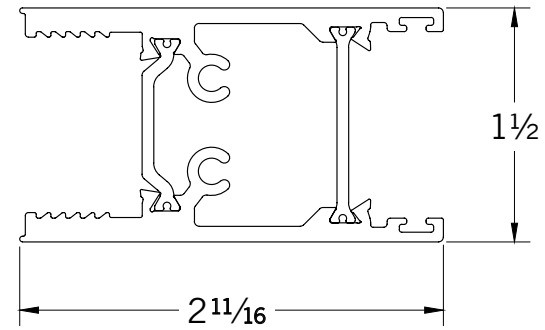



8113 THRESHOLD

8112 TRIM CAP

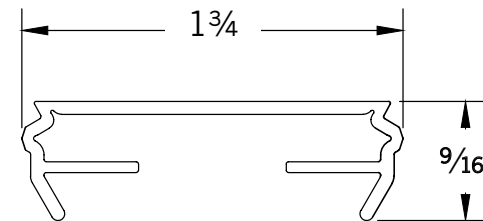
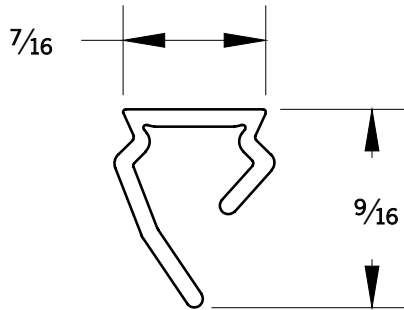

SERIES 8100 THERMALLY BROKEN ALUMINUM MULTI SLIDE DOOR

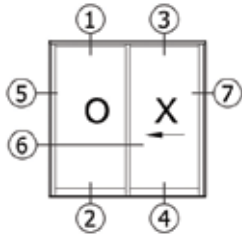

OX SLIDING DOOR

PAGE 15

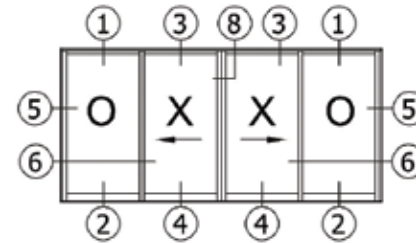

OXXO SLIDING DOOR

PAGE 19

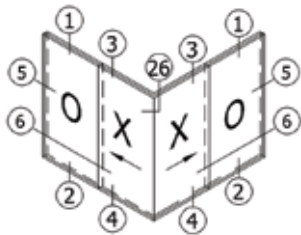

OXVXO CORNER DOOR

PAGE 16

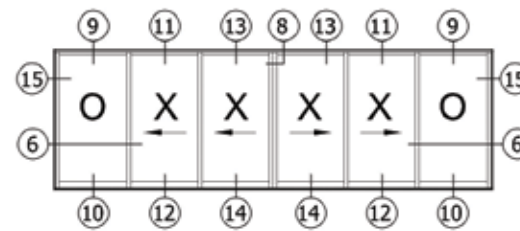

OXXXXO SLIDING DOOR

PAGE 20

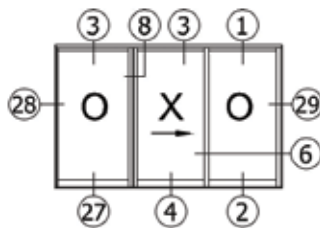

OXO SLIDING DOOR

PAGE 17

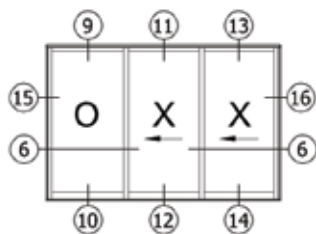

OXX SLIDING DOOR

PAGE 18

SERIES 8100 THERMALLY BROKEN ALUMINUM MULTI SLIDE DOOR

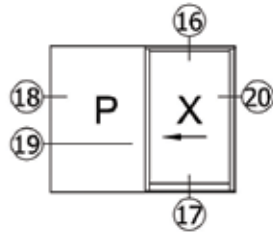

PX POCKET DOOR

PAGE 21

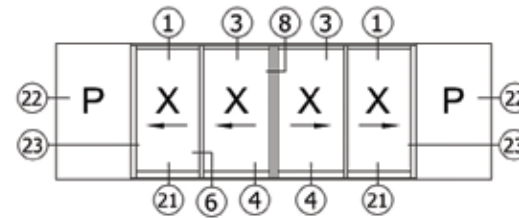

PXXXXP POCKET DOOR

PAGE 25

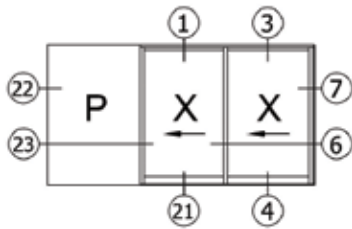

PXX POCKET DOOR

PAGE 22

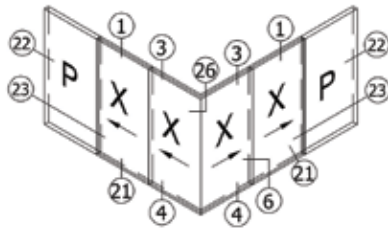

PXXVXXP POCKET DOOR

PAGE 23

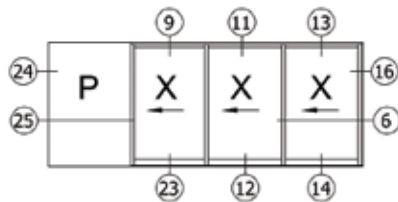

PXXX POCKET DOOR

PAGE 24



OX SLIDING DOOR

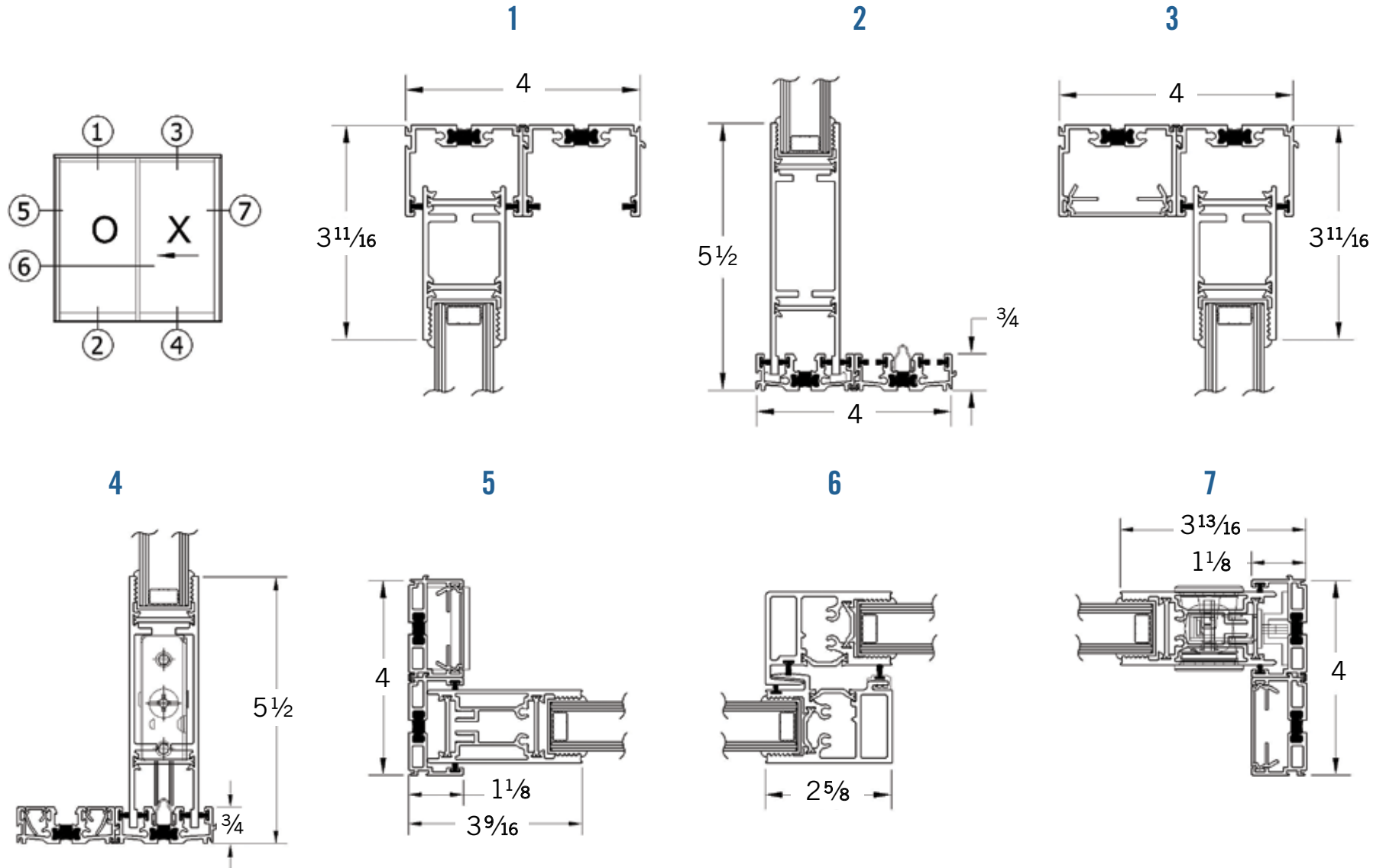

OXVXO CORNER DOOR

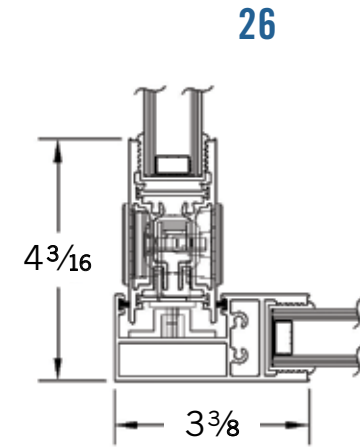
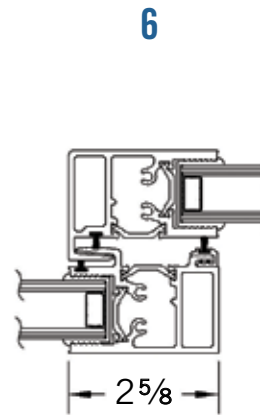
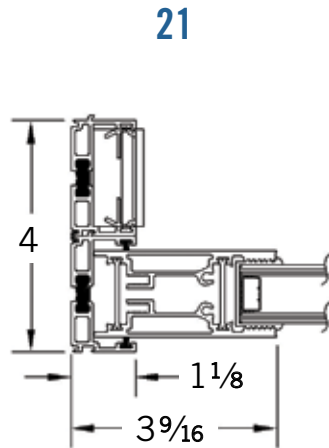
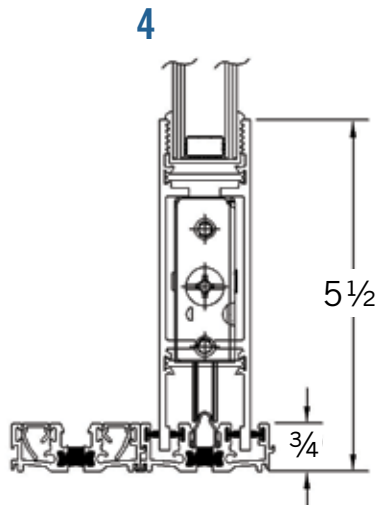
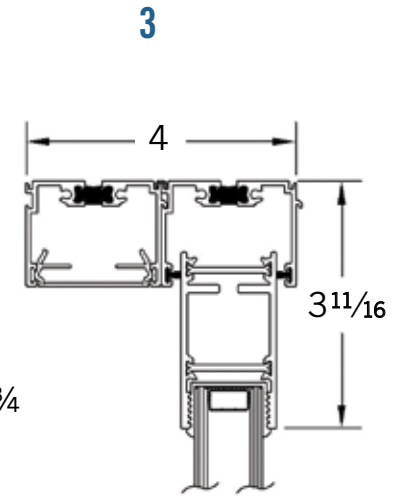
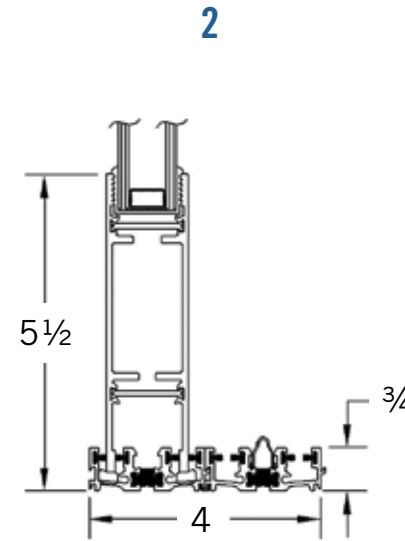
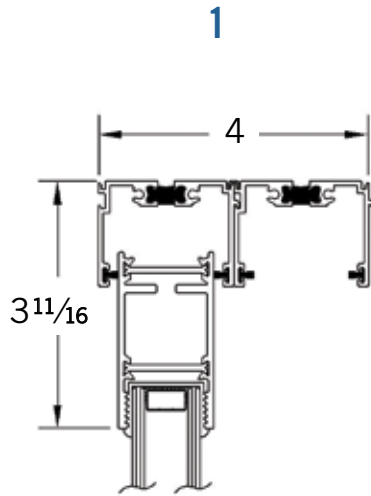
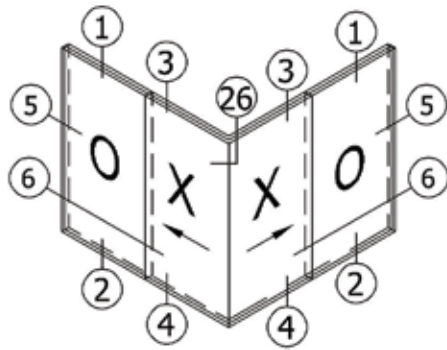

OXO SLIDING DOOR

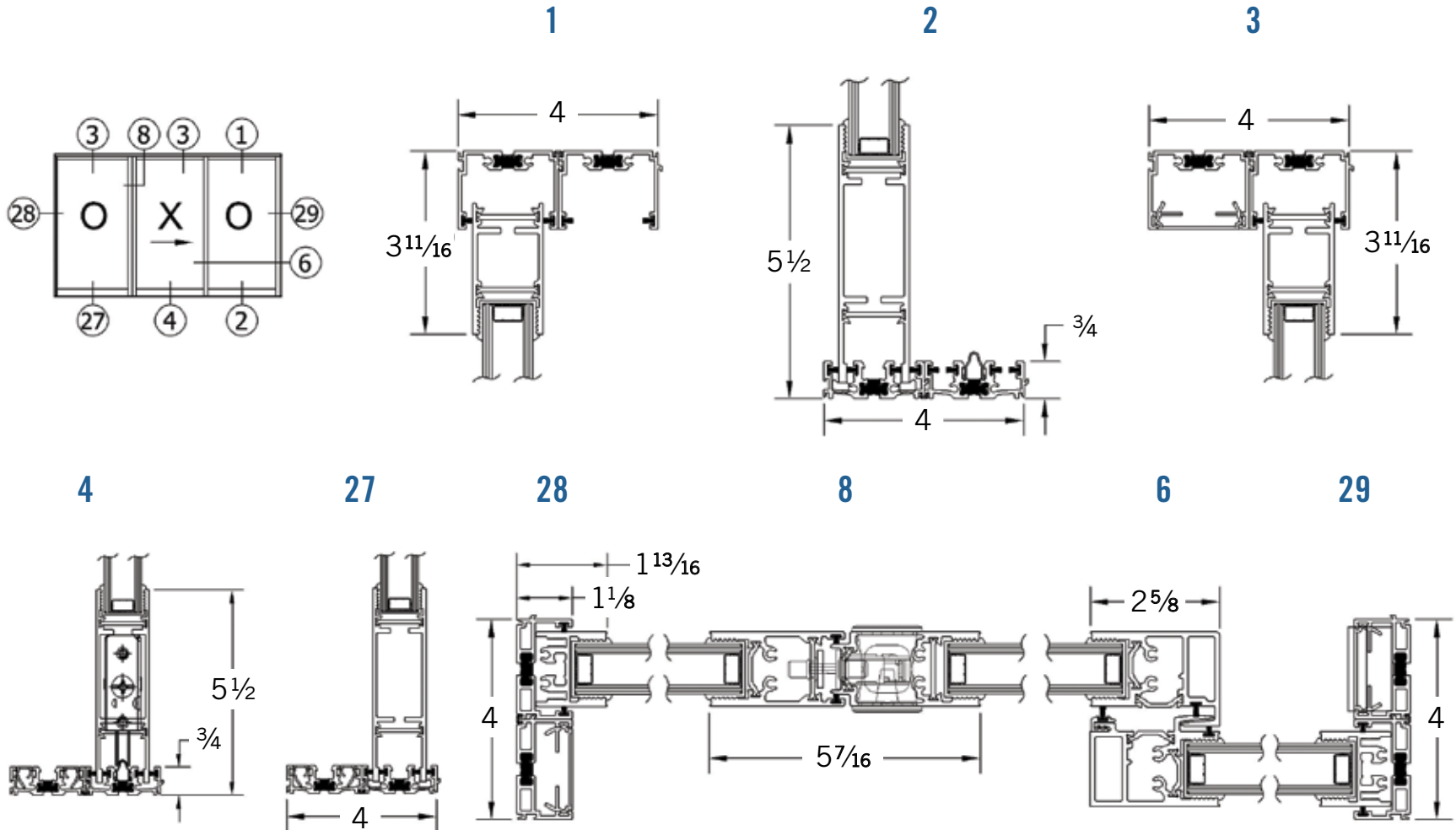

OXX SLIDING DOOR

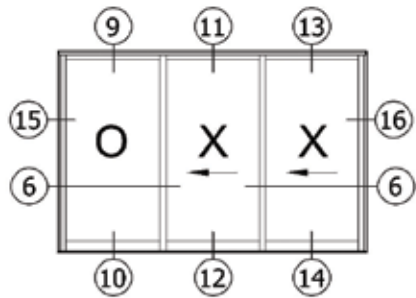

10

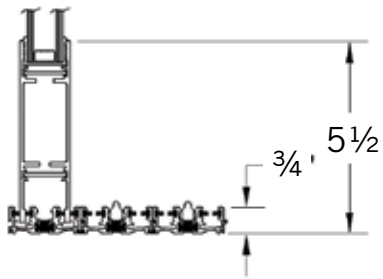

14

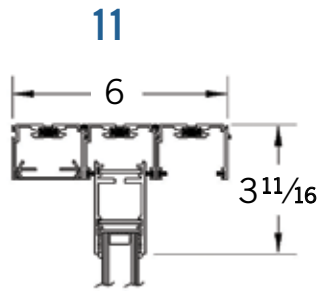
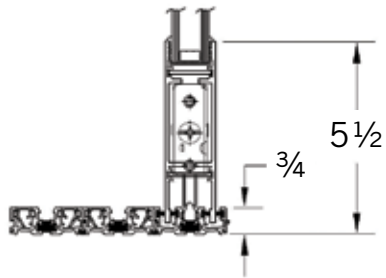

11

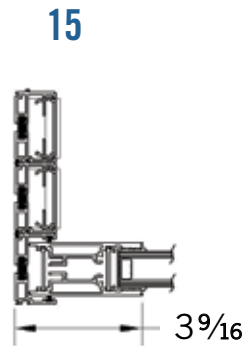

15

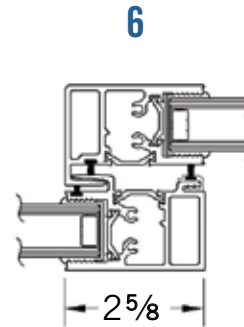

6

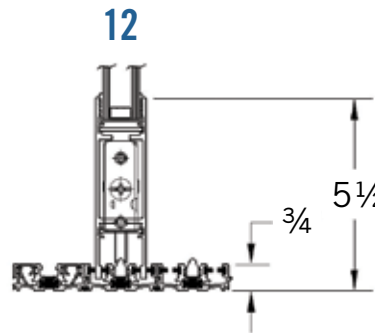

12

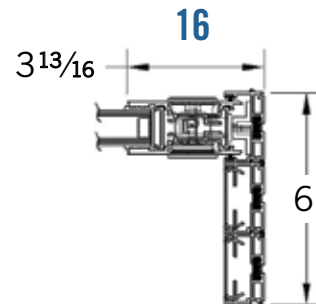

16

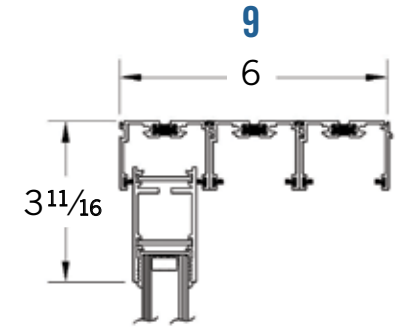

9

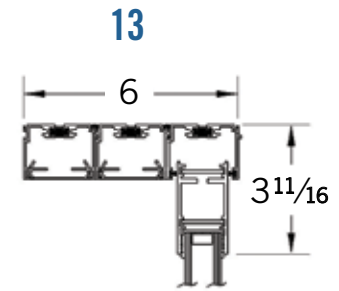

13



OXXO SLIDING DOOR

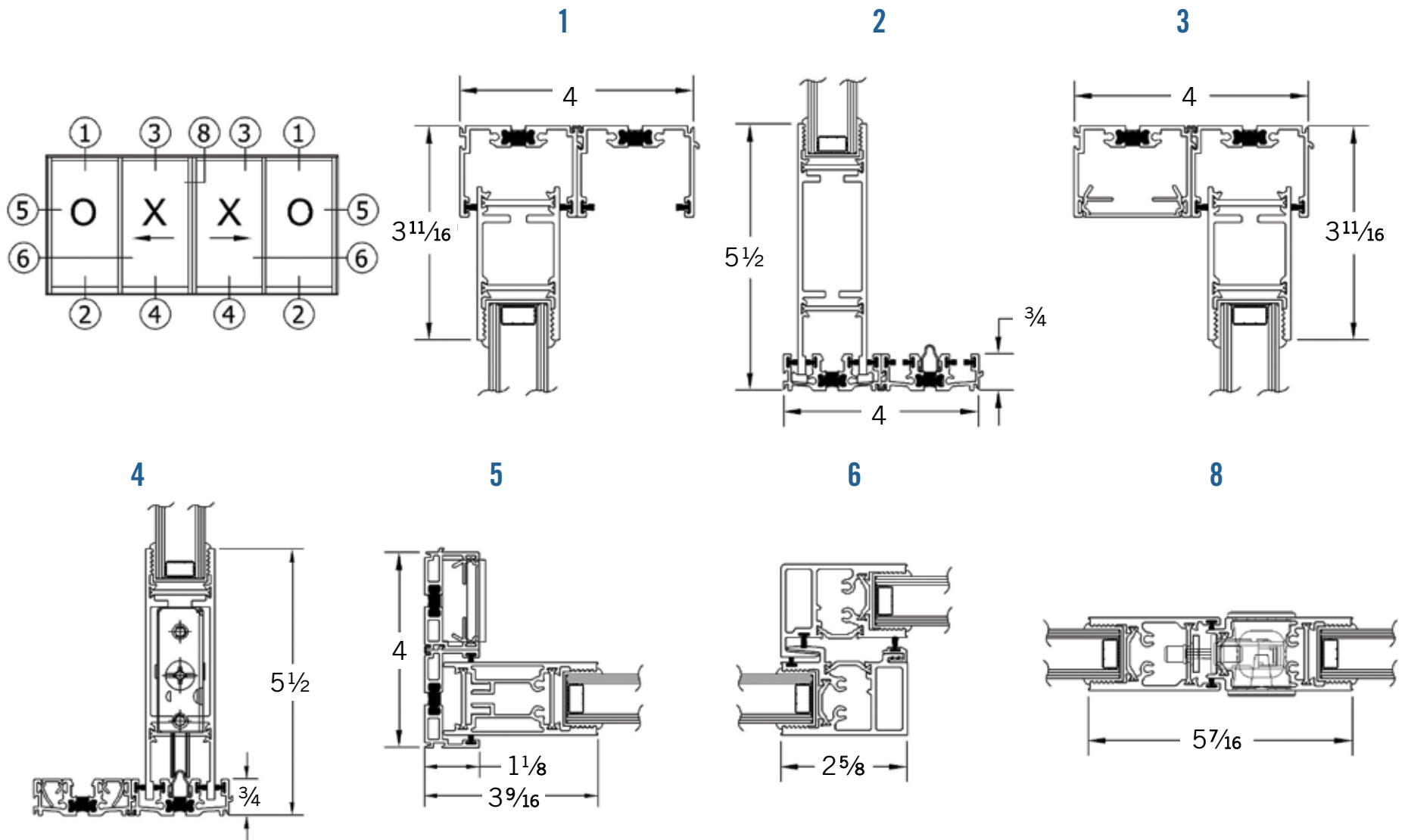

OXXXXO SLIDING DOOR

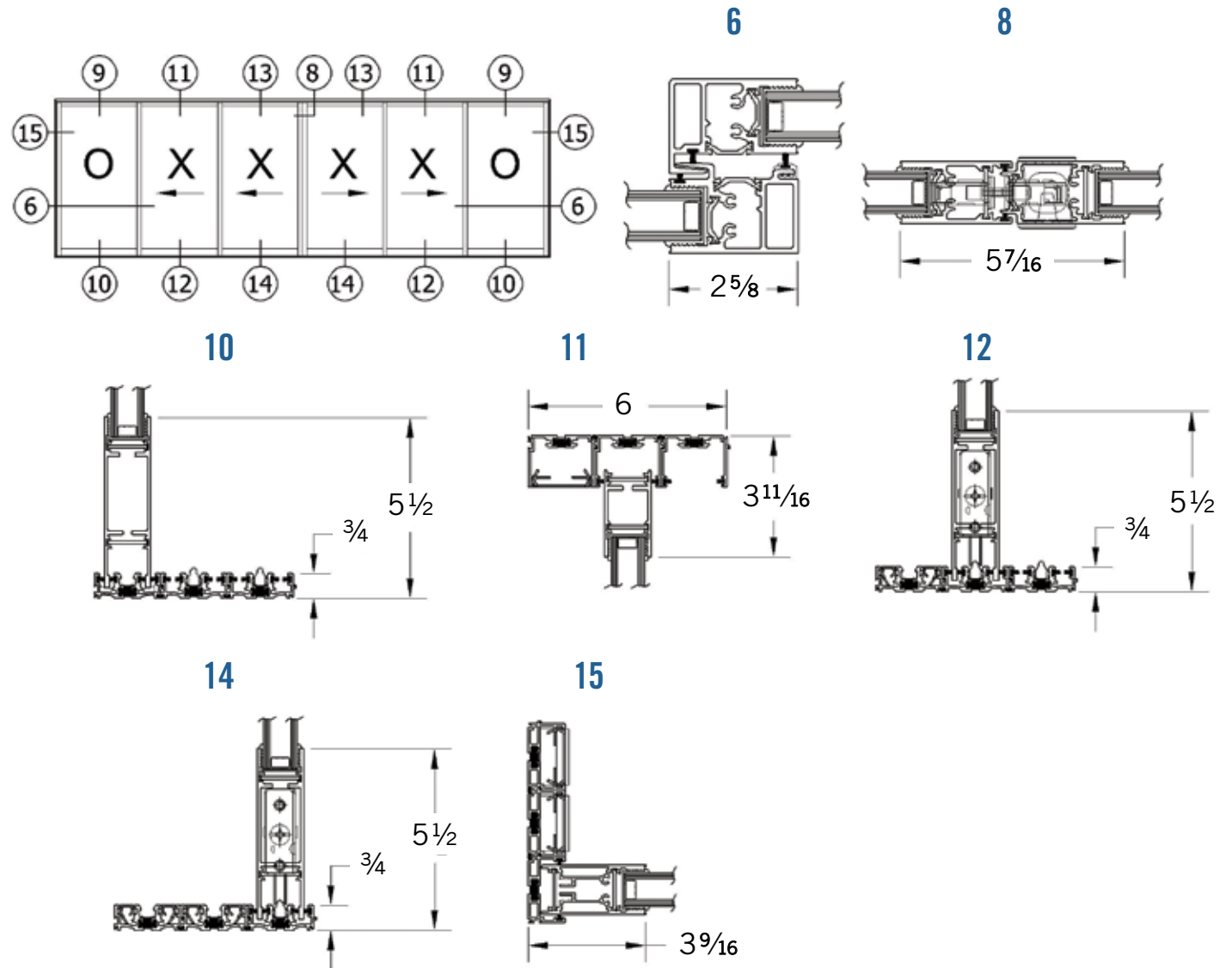

PX POCKET DOOR

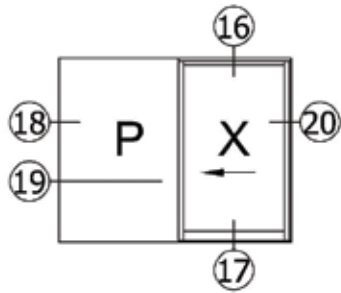

18

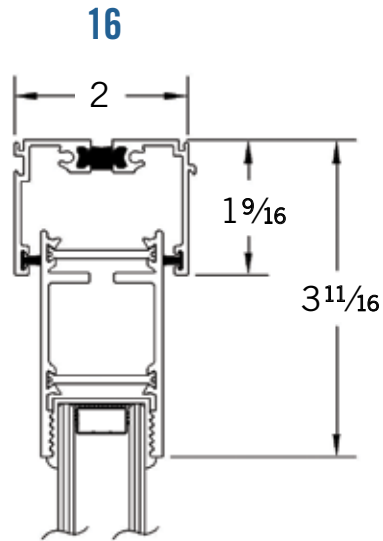
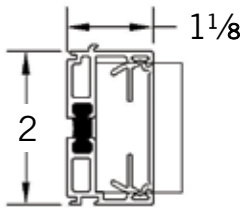

19

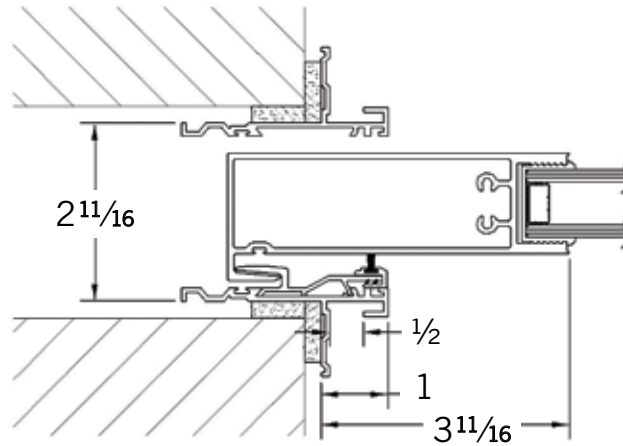

17

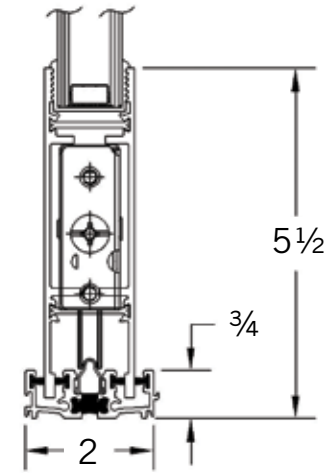

20

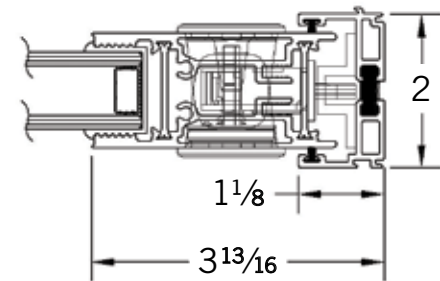

PXX POCKET DOOR

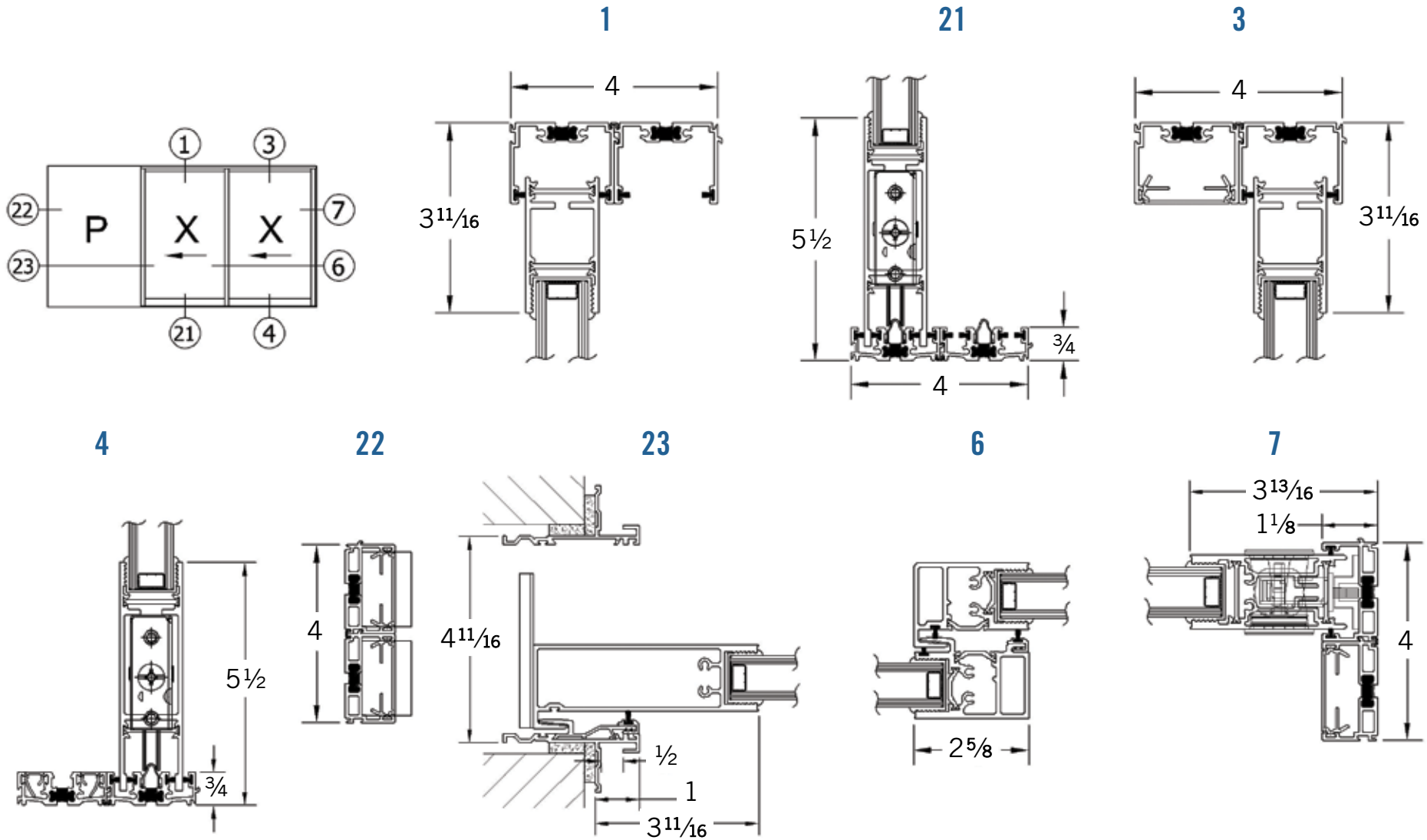

PXXVXXP CORNER POCKET DOOR

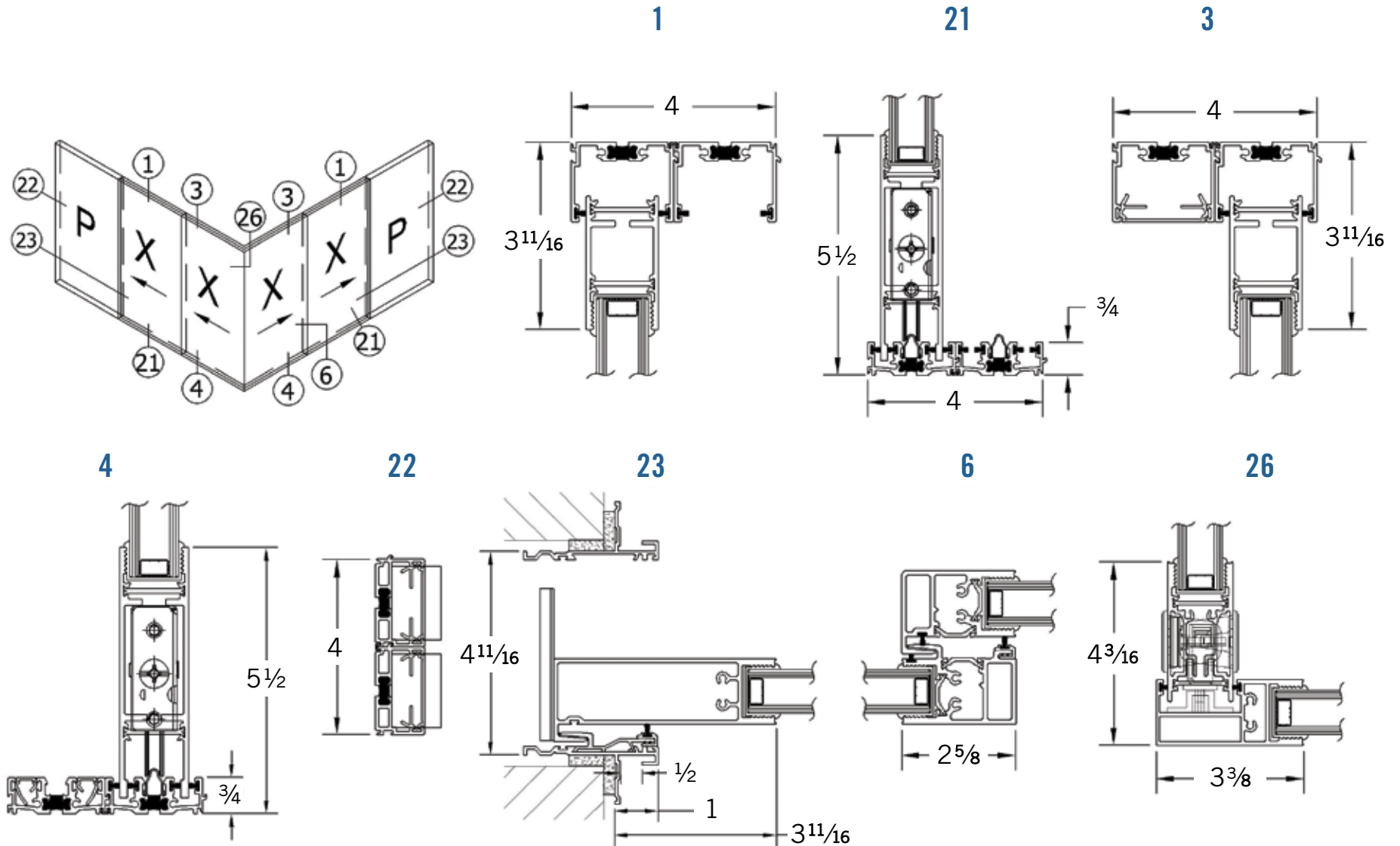

PXXX POCKET DOOR

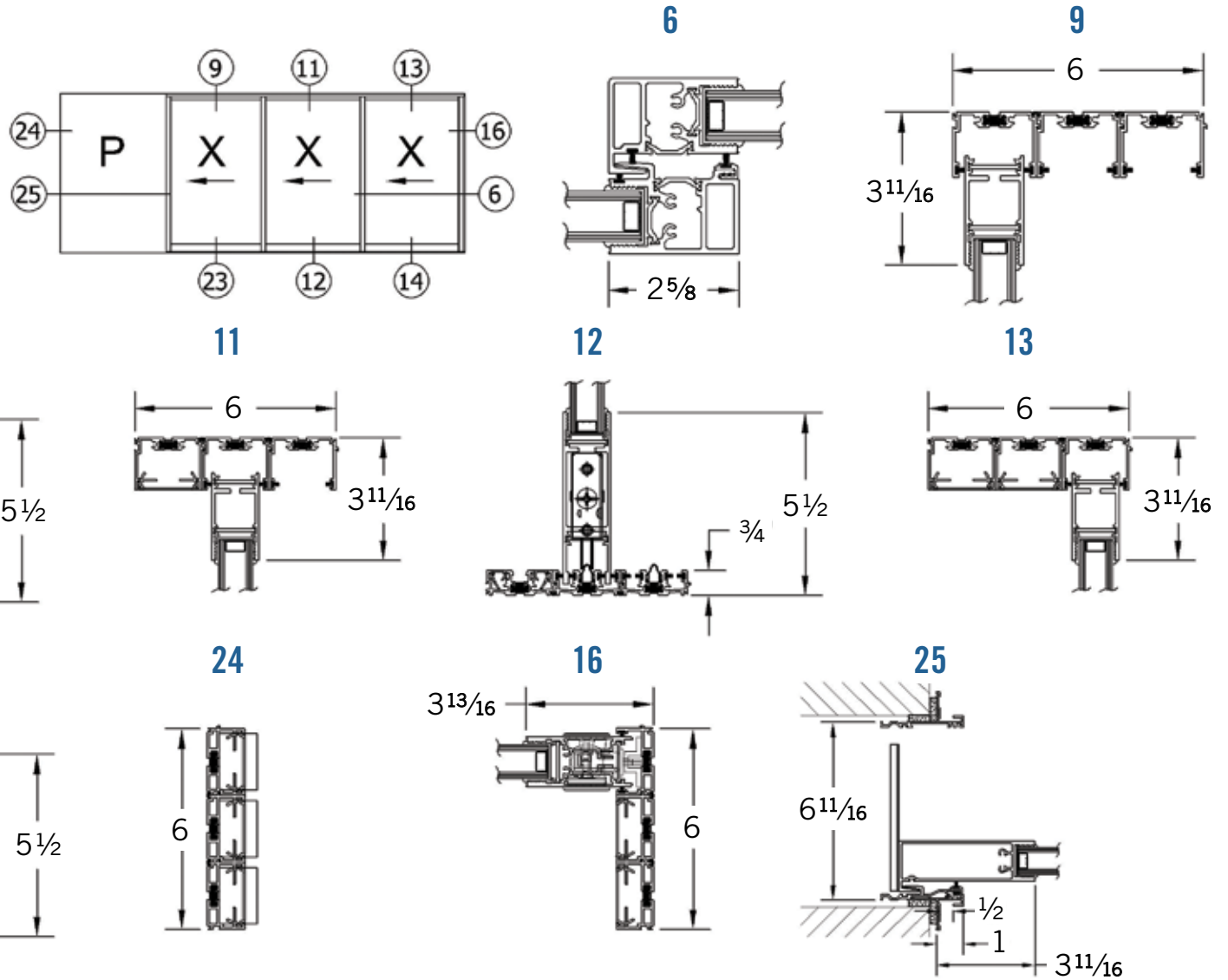

PXXXXP POCKET DOOR

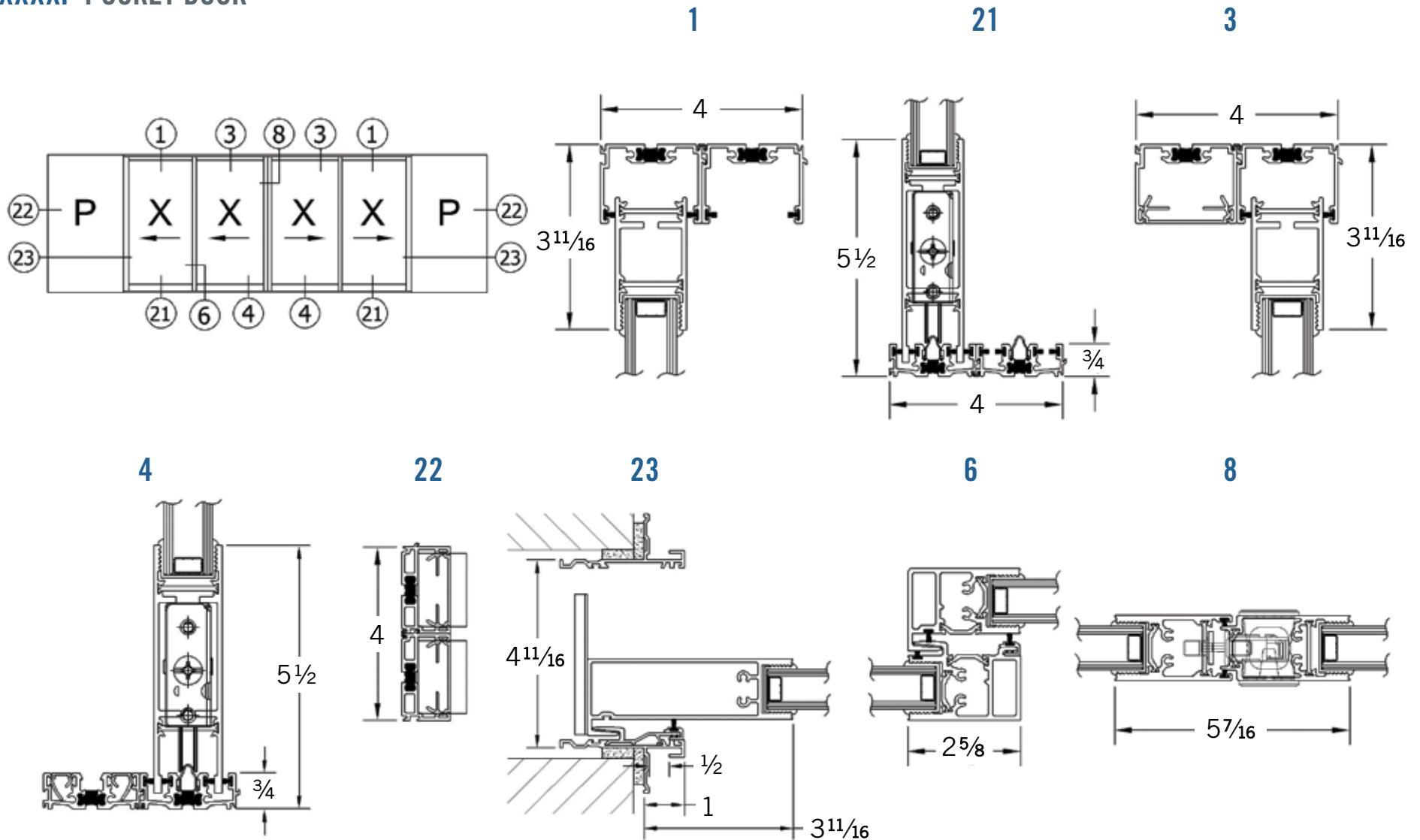



ALL WEATHER ARCHITECTURAL ALUMINUM TEST REPORT

SCOPE OF WORK
AAMA/WDMA/CSA 101/1.5.2/A440 TESTING ON 8100 SERIES SLIDING GLASS DOOR

REPORT NUMBER
J0388.01-301-44 R2

TEST DATE
11/06/18 - 01/16/19

ISSUE DATE **REVISION 2 DATE**
02/18/19 05/10/19

RECORD RETENTION END DATE
01/16/24

PAGES
27

DOCUMENT CONTROL NUMBER
RT-R-AMER-Test-2804 (04/17/18)
© 2017 INTERTEK



2531 E. Jansen Ave
Fresno, California 93706
Telephone: 559-233-8705
Facsimile: 713-764-4129
www.intertek.com/building

TEST REPORT FOR ALL WEATHER ARCHITECTURAL ALUMINUM

Report No.: J0388.01-301-44 R2
Date: 02/18/19

REPORT ISSUED TO
ALL WEATHER ARCHITECTURAL ALUMINUM
777 Aldridge Road
Vacaville, California 95688

SECTION 1
SCOPE

Intertek Building & Construction (B&C) was contracted by All Weather Architectural Aluminum to perform testing in accordance with AAMA/WDMA/CSA 101/1.5.2/A440 on their 8100 Series Sliding Glass Door. Results obtained are tested values and were secured by using the designated test method(s). Testing was conducted at the Intertek B&C test facility in Fresno, California. This report does not constitute certification of this product nor an opinion or endorsement by this laboratory.

SECTION 2
SUMMARY OF TEST RESULTS

TITLE	RESULTS
AAMA/WDMA/CSA 101/1.5.2/A440-11	Class CW – PG30: Size Tested 2400 x 2111 (94-1/2 x 83-1/8) – Type SD
Design Pressure	±1440 Pa (±30.08 psf)
Air Infiltration	1.5 L/s/m ² (0.29 cfm/ft ²)
Water Penetration Resistance Test Pressure	220 Pa (4.59 psf)

Reference must be made to Intertek B&C Report No. J0388.01-301-44 R0, dated 02/18/19 for complete test specimen description and detailed test results.

For INTERTEK B&C:

COMPLETED BY: Erick Caldero

REVIEWED BY: Tyler Westerling, P.E.

TITLE: Technician

TITLE: Senior Project Engineer

SIGNATURE: 
Applies Signatures to this Section

SIGNATURE: 
Applies Signatures to this Section

DATE: 05/10/19

DATE: 05/10/19

ECms

This report is for the exclusive use of Intertek's Client and is provided pursuant to the agreement between Intertek and its Client. Intertek's responsibility and liability are limited to the terms and conditions of the agreement. Intertek assumes no liability to any party, other than to the Client in accordance with the agreement, for any loss, expense or damage occasioned by the use of this report. Only the Client is authorized to permit copying or distribution of this report and then only in its entirety. Any use of the Intertek name or one of its marks for the sale or advertisement of the tested material, product or service must first be approved in writing by Intertek. The observations and test results in this report are relevant only to the sample(s) tested. This report by itself does not imply that the material, product, or service is or has ever been under an Intertek certification program.

intertek

Total Quality. Assured.

2524 E. Jansen Ave
Fresno, California 93706

Telephone: 559-239-6705
Facsimile: 559-239-4239
www.intertek.com/building

TEST REPORT FOR ALL WEATHER ARCHITECTURAL ALUMINUM

Report No.: J0388.01-301-44 R2

Date: 02/18/19

SECTION 3

TEST SPECIFICATION(S)/METHOD

The specimens were evaluated in accordance with the following:

AAAMA/WDMA/CSA 101/1.S.2/AA40-11 - North American Fenestration Standard/Specification for Windows, Doors, and Skylights

The following test methods were used during testing:

ASTM E283-04(2012), Standard Test Method for Determining Rate of Air Leakage Through Exterior Windows, Curtain Walls, and Doors Under Specified Pressure Differences Across the Specimen

ASTM E330/E330M-14, Standard Test Method for Structural Performance of Exterior Windows, Doors, Skylights and Curtain Walls by Uniform Static Air Pressure Difference

ASTM E547-00(2016), Standard Test Method for Water Penetration of Exterior Windows, Skylights, Doors, and Curtain Walls by Cyclic Static Air Pressure Difference

ASTM E997-00(2017), Standard Test Methods for Deglazing Force of Fenestration Products

ASTM E2068-00(2016), Standard Test Method for Determination of Operating Force of Sliding Windows and Doors

ASTM F842-17, Standard Test Methods for Measuring the Forced Entry Resistance of Sliding Door Assemblies, Excluding Glazing Impact

intertek

Total Quality. Assured.

2524 E. Jansen Ave
Fresno, California 93706

Telephone: 559-239-6705
Facsimile: 559-239-4239
www.intertek.com/building

TEST REPORT FOR ALL WEATHER ARCHITECTURAL ALUMINUM

Report No.: J0388.01-301-44 R2

Date: 02/18/19

SECTION 4

MATERIAL SOURCE/INSTALLATION

Test specimen was provided by the client. Representative samples of the test specimen(s) will be retained by Intertek B&C for a minimum of five years from the test completion date.

The specimen was installed into a Douglas-Fir wood buck. The rough opening allowed for a 1/4" shim space and the exterior perimeter of the specimen was sealed to the test buck.

LOCATION	ANCHOR DESCRIPTION	ANCHOR SPACING
Through frame	Double row of #8 x 2" PPH	Head and jamb 12" on center
Sill	Silicone sealant	Sill seated on 1/4" shims seated on sill pan using only silicone sealant
Sill pan	Silicone sealant	Sill pan seated onto wood buck using only silicone sealant

SECTION 5

LIST OF OFFICIAL OBSERVERS

NAME	COMPANY
David Douglass	Intertek B&C
Gino Vitali	Intertek B&C
Erick Caldera	Intertek B&C



Total Quality. Assured.

2524 E. Jensen Ave
Fresno, California 93706
Telephone: 559-233-8705
Facsimile: 717-756-4129
www.intertek.com/building

TEST REPORT FOR ALL WEATHER ARCHITECTURAL ALUMINUM

Report No.: J0388.01-301-44 R2
Date: 02/18/19

SECTION 6

TEST SPECIMEN DESCRIPTION

Product Type: Sliding Glass Door
Series/Model: 8100 Series

Product Size:

OVERALL AREA:	WIDTH		HEIGHT	
	Millimeters	Inches	Millimeters	Inches
5.37 m ² (57.8 ft ²)				
Overall size	2400	94-1/2	2111	83-1/8
Active panel	1220	48-1/16	2070	81-1/2
Fixed panel	1220	48-1/16	2070	81-1/2

Frame Construction:

MEMBER	MATERIAL	DESCRIPTION
Head, sill, jambs	Thermally broken aluminum	Broken by glass filled nylon
	JOINERY TYPE	DETAIL
All corners	Butted	Sealed; Four screws in each corner

Panel Construction:

MEMBER	MATERIAL	DESCRIPTION
Interlock	Aluminum	Thermal break between member and glazing bead
Rails and stiles	Thermally broken aluminum	Broken by glass filled nylon
	JOINERY TYPE	DETAIL
All corners	Butted	Sealed; Four screws in each corner

Reinforcement: No reinforcement was utilized.



Total Quality. Assured.

2524 E. Jensen Ave
Fresno, California 93706
Telephone: 559-233-8705
Facsimile: 717-756-4129
www.intertek.com/building

TEST REPORT FOR ALL WEATHER ARCHITECTURAL ALUMINUM

Report No.: J0388.01-301-44 R2
Date: 02/18/19

Weatherstripping:

DESCRIPTION	QUANTITY	LOCATION
Polypile with center fin	1 row	Interlock stiles
Polypile with center fin	5 rows	Sill
Polypile with center fin	2 rows	Jambs
Polypile with center fin (via attachment piece)	3 rows	Active panel interlock stile at sill corner

Glazing: No conclusions of any kind regarding the adequacy or inadequacy of the glass in any glazed test specimen(s) can be made.

GLASS TYPE	SPACER TYPE	INTERIOR LITE	EXTERIOR LITE	GLAZING METHOD
1" IG	Stainless steel	3/16" tempered	3/16" tempered	Dry glazed and secured by glazing bead with EPDM gasket

LOCATION	QUANTITY	DAYLIGHT OPENING		GLASS BITE
		Millimeters	Inches	
Fixed and active panel	2	1060 x 1860	41-3/4 x 73-1/4	1/2"

Drainages:

METHOD	SIZE	QUANTITY	LOCATION
Weephole	5/8" wide ovals	2 sets (4 per set)	Sill; 4-3/4" from corners

Hardware:

DESCRIPTION	QUANTITY	LOCATION
Roller track	1 row	Sill track; slip fit
Track clip	1	Hood track; snap-fit
Track filler	1	Sill; snap-fit
Roller assembly	2	Bottom rail of active panel
Latch	1	Lock stile
Keeper	1	Lock jamb; opposite lock stile
Handle	1	Lock stile; 3" below latch

Screen Construction: No screen construction was utilized.



intertek

Total Quality. Assured.

2524 E. Jansen Ave
Fresno, California 93706
Telephone: 559-239-8700
Facsimile: 559-239-4129
www.intertek.com/building

TEST REPORT FOR ALL WEATHER ARCHITECTURAL ALUMINUM

Report No.: J0388.01-301-44 R2

Date: 02/18/19

SECTION 7

TEST RESULTS

The temperature during testing was 20°C (68°F). The results are tabulated as follows:

Test Specimen #1:

TITLE OF TEST	RESULTS	ALLOWED	NOTE
Operating Force, per ASTM E2068			
Initiate Motion:	75 N (17 lbf)	180 N (40.5 lbf) max	
Maintain Motion:	53 N (12 lbf)	115 N (25.9 lbf) max	
Latches:	36 N (8 lbf)	100 N (22.5 lbf) max	
Air Leakage, infiltration per ASTM E283 at 75 Pa (1.57 psf)	1.5 L/s/m ² (0.29 cfm/ft ²)	1.5 L/s/m ² (0.3 cfm/ft ²) max.	1, 2
Water Penetration, per ASTM E547 at 220 Pa (4.59 psf)	Pass	No leakage	3
Uniform Load Deflection, per ASTM E330 Deflections taken at interlock			
+1440 Pa (+30.08 psf)	11.9 mm (0.47")	11.9 mm (0.47")	3, 4,
-1440 Pa (-30.08 psf)	11.9 mm (0.47")	11.9 mm (0.47")	5
Uniform Load Structural, per ASTM E330 Permanent set taken at interlock			
+2160 Pa (+45.11 psf)	0.3 mm (0.01")	8.1 mm (0.32") max.	
-2160 Pa (-45.11 psf)	0.3 mm (0.01")	8.1 mm (0.32") max.	3, 4, 5
Forced Entry Resistance, per ASTM F842, Type: A - Grade: 10	Pass	No entry	
Deglazing, per ASTM E987 Operating direction, 320 N (70 lbf)	Pass	Meets as stated	
Remaining direction, 230 N (50 lbf)	Pass	Meets as stated	

intertek

Total Quality. Assured.

2524 E. Jansen Ave
Fresno, California 93706
Telephone: 559-239-8700
Facsimile: 559-239-4129
www.intertek.com/building

TEST REPORT FOR ALL WEATHER ARCHITECTURAL ALUMINUM

Report No.: J0388.01-301-44 R2

Date: 02/18/19

SECTION 8

ALTERATIONS

Note 1: The tested specimen meets (or exceeds) the performance levels specified in AAMA/WDMA/CSA 101/LS2/A440 for air leakage resistance.

Note 2: Test Date 11/06/18 / Time: 08:15 AM

Note 3: The client opted to start at a pressure higher than the minimum required.

Note 4: Loads were held for 10 seconds.

Note 5: Tape and film were not used to seal against air leakage during structural testing.

No alterations were required.